

# ERCHONIA FX 635 OPERATION & MAINTENANCE MANUAL



## Quick Links

[Service and Repair](#)

[Preset Protocols](#)

[User Protocols for Other Pain Indications](#)

[Laser Head Assembly Removal & Installation for Service](#)

[Technical Specifications](#)

# Table of Contents

Table of Contents

SECTION 1 GENERAL INFORMATION

PRODUCT DESCRIPTION

PACKAGE CONTENTS

SYMBOLS USED ON THE EQUIPMENT

SAFETY INFORMATION

NOTIFICATION OF ADVERSE EVENTS

ERCHONIA LASER INDICATIONS FOR USE

TECHNICAL INFORMATION

SERVICE AND REPAIR

SECTION 2 PRODUCT OVERVIEW

NOMENCLATURE

SECTION 3 SETUP & OPERATION

WHEEL LOCKS

MAIN ARM & LASER HEAD ASSEMBLY OPERATION

POWERING UP THE DEVICE

PRESET PROTOCOLS

USER PROTOCOLS FOR OTHER PAIN INDICATIONS

QUICK PROGRAM FOR OTHER PAIN INDICATIONS

CREDIT & DEVICE INFORMATION SCREEN

HOW DO CREDITS WORK

TO ADD CREDITS

LABELS

SECTION 4 PROFESSIONAL USE INSTRUCTIONS

APPLICATION/ADMINISTRATION

HEEL PROTOCOL

LOW BACK PROTOCOL

NECK PROTOCOL

SHOULDER PROTOCOL

ELBOW PROTOCOL

WRIST/HAND PROTOCOL

[KNEE PROTOCOL](#)

[ANKLE/FOOT PROTOCOL](#)

[PRE-OP PROTOCOL](#)

[POST-OP PROTOCOL](#)

[USER PROTOCOLS](#)

[QUICK PROGRAM PROTOCOL](#)

[CLINICAL TRIAL SUMMARIES](#)

[SECTION 5 MAINTENANCE & WARRANTY INFORMATION](#)

[MAINTENANCE AND CLEANING](#)

[FUSE REPLACEMENT](#)

[WARRANTY](#)

[CONTACT US](#)

[LASER HEAD ASSEMBLY REMOVAL & INSTALLATION FOR SERVICE](#)

[GUIDANCE AND MANUFACTURER'S DECLARATION-  
ELECTROMAGNETIC EMISSIONS & IMMUNITY](#)

[TECHNICAL SPECIFICATIONS](#)

[Other ManualsLib Projects](#)



**ERCHONIA**  
*World Leaders in Low Level Laser Technology*

**FX635**



Operation &  
Maintenance  
Manual

**Read this entire booklet before using your FX 635 Laser**

## READ THIS FIRST

To ensure proper use, and to achieve your best results, it is important that you read and understand the instructions, warnings, precautions and safety information in this booklet before using your FX 635 laser for the first time.



This symbol appears next to information about possible safety risks.

Questions? Our Erchonia Customer Care representatives are available to help. Contact us at:

**Erchonia Customer Care**

Phone: 1-321-473-1251

Email: [info@erchonia.com](mailto:info@erchonia.com)

Or visit [erchonia.com](http://erchonia.com)

**ATTENTION:** By purchasing this Erchonia device, you, the licensed health care professional, acknowledge that you are solely responsible to ensure: (i) that your use of this device is within the scope of your professional practice; and (ii) that you use the device in accordance with all applicable laws, rules, and regulations, including without limitation, any regulations promulgated by any state medical or professional board applicable to your practice.

We recommend you periodically contact Erchonia Corporation to determine if additional product information updates are available.

**TABLE OF CONTENTS**

**SECTION 1 GENERAL INFORMATION**..... 1

    PRODUCT DESCRIPTION..... 1

    PACKAGE CONTENTS..... 1

    SYMBOLS USED ON THE EQUIPMENT..... 2

    SAFETY INFORMATION ..... 3

    NOTIFICATION OF ADVERSE EVENTS ..... 6

    ERCHONIA LASER INDICATIONS FOR USE ..... 6

    TECHNICAL INFORMATION..... 6

    SERVICE AND REPAIR..... 6

**SECTION 2 PRODUCT OVERVIEW**..... 7

    NOMENCLATURE ..... 7

**SECTION 3 SETUP & OPERATION**..... 13

    WHEEL LOCKS ..... 13

    MAIN ARM & LASER HEAD ASSEMBLY OPERATION..... 13

    POWERING UP THE DEVICE..... 17

    PRESET PROTOCOLS..... 18

    USER PROTOCOLS FOR OTHER PAIN INDICATIONS..... 20

    QUICK PROGRAM FOR OTHER PAIN INDICATIONS..... 23

    CREDIT & DEVICE INFORMATION SCREEN..... 26

    HOW DO CREDITS WORK?..... 26

    TO ADD CREDITS..... 27

    LABELS ..... 28

**SECTION 4 PROFESSIONAL USE INSTRUCTIONS**..... 31

    APPLICATION/ADMINISTRATION..... 31

    HEEL PROTOCOL ..... 31

    LOW BACK PROTOCOL ..... 32

    NECK PROTOCOL..... 33

    SHOULDER PROTOCOL ..... 33

    ELBOW PROTOCOL ..... 34

    WRIST/HAND PROTOCOL ..... 34

    KNEE PROTOCOL..... 34

    ANKLE/FOOT PROTOCOL ..... 35

    PRE-OP PROTOCOL..... 35

    POST-OP PROTOCOL ..... 35

    USER PROTOCOLS ..... 36

    QUICK PROGRAM PROTOCOL..... 36

    CLINICAL TRIAL SUMMARIES ..... 37

**SECTION 5 MAINTENANCE & WARRANTY INFORMATION** ..... 41

MAINTENANCE AND CLEANING ..... 41  
FUSE REPLACEMENT..... 41  
WARRANTY ..... 42  
CONTACT US..... 43  
LASER HEAD ASSEMBLY REMOVAL & INSTALLATION FOR SERVICE ..... 44  
GUIDANCE AND MANUFACTURER’S DECLARATION-ELECTROMAGNETIC EMISSIONS &  
IMMUNITY ..... 46  
TECHNICAL SPECIFICATIONS ..... 49

## SECTION 1 GENERAL INFORMATION

This Erchonia® FX 635, model: HPS Operator's Guide is designed to take you through set-up and proper use of your device. It will cover the Device Overview, Operation, Cautions, Warnings, Professional Use Instructions and Maintenance and Warranty Information.

It is important that you read and understand all of the information contained in this operator's guide before performing any treatments with the Erchonia® FX 635. If you have any questions, contact our Erchonia Customer Care representatives.

### PRODUCT DESCRIPTION

The Erchonia® FX-635 (Model#: HPS) is low level laser system that uses three semi-conductor diodes (visible red-light) 630nm to 650nm with a mean power output of 17.25mW per diode. The Erchonia® FX-635™ (Model#: HPS) is a variable hertz device. The variable hertz feature of the Erchonia® FX-635™ (Model#: HPS) is a pulsed wave, defined as containing a selected series of breaks, variances that are preprogrammed. The Erchonia® FX 635 (Model#: HPS) has been classified by the FDA/EC as a Class II device and a Class 2 Laser.

The components of the device include a mobile base which plugs into the wall, using a hospital grade power cord, equipped with a medical grade transformer. Four (4) antistatic wheels that enable ease for maneuverability. A touch screen that functions as a display screen and input panel. The touch screen communicates with the PCB to initiate, stop or pause the energy flow to the laser diodes. The laser diodes can only be on or off; there is no user interface that allows the end user to alter the laser diode output. The device has an adjustable main arm that is attached to the mobile base with the laser head assembly located at the end. The adjustable main arm is capable to collapse into the mobile base for storage and transporting or extends to position the laser heads above the area of involvement. The laser head assembly that is attached to the adjustable main arm that is manually raised and lowered utilizes internal mechanics that collects the light emitted from each of the three (3) laser diodes and processes each through a proprietary patented lens which redirects the beam with a line refractor. The refracted light is then bent into a spiraling circle pattern that is totally random and independent of the other diodes. When the laser head assembly is positioned 3-4 inches from the patient's skin each diode delivers .51J per minute. This assembly can be rotated 120 degrees for proper positioning to patient for accurate treatment. The laser head assembly includes arms and pivots that allow the three (3) laser output heads to be rotated, tilted, and raised / lowered independently. The device contains software that is loaded into the PCB drivers. This data includes the touch screen images (GUI) and the command prompts that activate the screen icons; work in conjunction with the component platform to ensure the device operates as intended. The exterior materials consist of 6061 T6 AL, Kydex 430 and Copolymer Acetal with powder coating and carbon fiber finish.

### PACKAGE CONTENTS











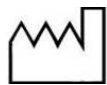

Erchonia® FX 635 is shipped in one large packing box with two components:

- FX 635 device
- Accessories (small box)
  - Safety glasses
  - Keys
  - Manual
  - Power Cord
  - Height Extension Block w/ Locking Knob

When you receive the shipment, carefully inspect the container for damage. If the shipping container or cushion material is damaged, keep it until the contents have been checked for completeness and the device has been checked for proper function. If the contents are incomplete or if there is mechanical damage, contact Erchonia Corporation at 1-321-473-1251. If the shipping container is damaged, also notify the carrier.

## SYMBOLS USED ON THE EQUIPMENT



Any or all of the following symbols may be used in this manual or on this equipment:

SYMBOL	DESCRIPTION
	Temperature Limitation
	Type B patient connection - applied parts that are generally not conductive and can be immediately released from the patient.
	<b>Conformité Européenne</b> - Complies with EMC 2004/108/EC and LVD 2006/95/EC
	Power ON
	Power OFF
	Date of Manufacture
	Manufacturer
	Authorized representative in the European Community.
	Refer to Operating Instructions.
	<b>Warning</b> alerts you about a situation which, if not avoided, could result in death or serious injury. It may also describe potential serious adverse reactions and safety hazards.
	<b>Caution</b> is used for the statement of a hazard alert that warns you of a potentially hazardous situation which, if not avoided, may result in minor or moderate injury to the user or patient or damage to the equipment or other property. It may also be used to alert against unsafe practices. This includes the special care necessary for the safe and effective use of the device and the care necessary to avoid damage to a device that may occur as a result of use or misuse.
	Do not Push-No pushing in this direction
	Pinch point-keep hands clear
<b>Rx Only</b>	Prescription only (In the US, Federal law restricts this device to sale by or on the order of a physician)
	<b>DO NOT</b> stare into laser beam







## SAFETY INFORMATION

Read the following important safety information before using the FX 635 laser.

### WHEN NOT TO USE

	Safety of non-thermal lasers for use over a pregnant uterus has not been established.
	<p><b>DO NOT</b> use if the following conditions exist:</p> <ul style="list-style-type: none"><li>➤ Inflammatory: seronegative spondylarthritides (e.g. ankylosing spondylitis); rheumatoid arthritis; infection - epidural abscess or osteomyelitis</li><li>➤ Neoplastic: bone tumors (primary or metastatic); and intradural spinal tumors</li><li>➤ Metabolic: osteoporotic fractures; osteomalacia; ochronosis; and chondrocalcinosis.</li><li>➤ Psychosomatic: Tension myositis syndrome</li><li>➤ Current, active chronic pain disease: chronic fatigue syndrome, fibromyalgia, endometriosis, inflammatory bowel disease, interstitial cystitis.</li><li>➤ Cancer or treatment for cancer in the past 6 months, including tumors of the spinal cord</li></ul>

### WARNINGS

	You must follow these Instructions for Use when using the FX 635 laser. Not following these instructions may result in serious injury.
	<p><b>DO NOT</b> permit any foreign materials or liquids to enter the device. Take care to prevent any foreign materials including, but not limited to, inflammables, water, and metallic objects from entering the device. These may cause device damage, malfunction, electrical shock, fire, or personal injury. To achieve the specified level of protection against spilled or splashed liquids, unplug the device from the power supply and thoroughly dry all exposed surfaces of this device and allow to dry thoroughly prior to operation.</p>
	<p><b>DO NOT</b> disassemble, modify, or remodel the device or accessories. This may cause device damage, malfunction, electrical shock, fire, or personal injury.</p>
	To avoid risk of electric shock, do not defeat the safety purpose of the grounding-type plug. A grounding-type plug has two blades and a third grounding prong. The wide blade or third prong is provided for your safety. If the provided plug does not fit into your outlet, consult an electrician.
	<p><b>DO NOT</b> submerge any part of the device in water. This could damage the device, or cause an electric shock that may lead to serious injury or death.</p>
	Use of controls or adjustments or performance of procedures other than those specified herein may result in hazardous radiation exposure.
	This equipment/system may cause radio interference or may disrupt the operation of nearby equipment. It may be necessary to re-orient or relocate the ME equipment or shielded the location. The long-term effects of prolonged use of non-thermal laser exposure are unknown.

---

## WARNINGS (Continued)

---



Dispose of device in accordance with local and national regulations and codes. When spent and beyond repair or functional use, the device can be sent back to the manufacture for disposal. This ensures the proper separation and handling of all the internal parts and reduces any risk to the end user and the environment.



Risk of explosion if used in the presence of flammable anesthetics. Use of this device in an oxygen-enriched environment may produce potential of fire hazard. This device is not suitable for use in the presence of a flammable anesthetic mixture with air or with oxygen or nitrous oxide.



Avoid direct contact of the laser beam into the eyes. Laser protective eyewear should be worn by the patient to block light energy from the eyes during treatment.



**DO NOT** use over sensitive skin areas or in the presence of poor circulation; Laser treatment should be applied only to normal, intact, clean skin or treatment will not be effective.



Laser treatment should not be applied over open wounds or over swollen, infected, or inflamed areas or skin eruptions, e.g., phlebitis, thrombophlebitis, varicose veins, etc. as conclusive tests have not been conducted.











Laser treatment should not be applied over, or in proximity to, cancerous lesions as conclusive tests have not been conducted.



The safety and effectiveness of this device has not been demonstrated for patients with the following conditions: apophyseal osteoarthritis; diffuse idiopathic skeletal hyperostosis; degenerative discs; Scheuermann's kyphosis; s ("slipped disc"); thoracic or lumbar spinal stenosis; spondylolisthesis and other congenital abnormalities; fractures; leg length difference; restricted hip motion; misaligned pelvis - pelvic obliquity; anteversion or retroversion; and abnormal foot pronation.

## CAUTIONS

	In the US, Federal law restricts this device to sale by or on the order of a physician.
	This device should only be used under the supervision of a suitably qualified and licensed healthcare professional.
	Read, understand, and practice the precautionary and operating instructions. Know the limitations and hazards associated with using any laser device. Observe the precautionary and operational decals placed on the device. If you have difficulty operating the device after carefully reviewing this reference guide, contact our Erchonia Customer Care representatives for assistance.
	<b>DO NOT</b> position equipment so that in an emergency it is difficult to disconnect the power cord from the electric supply.
	<b>DO NOT</b> place/operate this device in close proximity (6 inches) to other devices that emit frequency. If this device causes interference to other devices, which can be determined by turning the device off and on, you are encouraged to try to correct the interference by one of the following measures: <ul style="list-style-type: none"><li>• Reorient or relocate the receiving device.</li><li>• Increase the separation between the equipment.</li><li>• Connect the equipment into an outlet on a circuit different from that to which the other device(s) are connected.</li></ul>
	This device should be operated in temperatures between 59° to 85°F (15° to 29°C), and transported in temperatures between -22° to 158°F (-30° to 70°C), with relative humidity less than 75%.
	There are no user-serviceable parts inside the device except the fuses. If a malfunction occurs, discontinue use immediately and contact Erchonia® Corporation for repair service.
	Inspect electrical cord and associated connectors before each use. <b>ONLY</b> use the power cord supplied with the device. Using a different power cord could damage the device.
	Physicians should exercise caution if the patient has sensitive skin areas or in the presence of poor circulation.

## NOTIFICATION OF ADVERSE EVENTS

As a health care provider, you may have responsibilities under the Medical Device Reporting for User Facilities (FDA 21 CFR part 803), or the local government Vigilance reporting requirements to report, the occurrence of events that include device-related death and serious injury or illness. If such an event is brought to your attention, to ensure compliance; contact both the Agent identified on the label and the manufacturer, Erchonia Corporation. As part of our Quality Assurance Program, Erchonia Corporation requests to be notified of device failures or malfunctions. This information is required to ensure that Erchonia Corporation provides only the highest quality products.

## ERCHONIA LASER INDICATIONS FOR USE

The Erchonia® FX-635™ is indicated for the adjunctive use in providing temporary relief of nociceptive musculoskeletal pain.

## TECHNICAL INFORMATION

Technical documentation required by the customer, in case of necessary reparations, will be provided by Erchonia in the US and our EU agent, internationally. These documents will be supplied once the manufacturer makes the determination that the requested documents do not constitute a disclosure of proprietary or patent protected information and are a part of the filed and documented technical file.

## SERVICE AND REPAIR

If a device requires service, contact the Erchonia Service and Repair Department at:  
Telephone: 1-321-473-1251

When requesting service or repair, please provide the following information to the service representative:

- Device serial number (located on the back label)
- Description of the problem
- Name of the person to contact

### *RETURNING A DEVICE FOR SERVICE*

- Before sending a device to the Erchonia Service and Repair Department for repair, obtain a service order (SO) number from the service representative.
- Pack the device and charger in the original containers (if available) or equivalent packaging. Be sure the assigned service order number appears on the package.

### **Return the Device to:**

Erchonia Corporation  
650 Atlantis Rd.  
Melbourne, FL 32904 USA  
Attention: Service and Repair Department (*SO Number*)

**NOTE:** For international customers, PRIOR to sending a unit in for repair you must obtain from the Erchonia Service department an annually revised FDA Form 2877. The Radiation Control form (2877) will be sent to you partially complete, containing regulatory information. To complete, fill in the unique information associated with your device and the shipment thereof; such as serial number, port, etc. The completed form 2877 must accompany your shipment affixed to the outside of the package. Failure to include the form in the shipment may result in customs delays and fines. Any resulting fines are the responsibility of the customer.

## SECTION 2 PRODUCT OVERVIEW

### NOMENCLATURE

The Erchonia® FX 635 emits a 640 nanometer wavelength with a tolerance of  $\pm 10$  nanometer, from each of the three specially created and patented electronic diodes.

The Erchonia® FX 635 laser is manufactured in accordance to the Good Manufacturing Procedures consistent with national regulatory agencies; such as FDA, EU, HC, TGA, and Anvisa. Per ISO and FDA standards the device and lasers are classified as Class 2.

Each of these governing agencies requires specific labeling. Required labels are affixed according to the relevant codes. Each label is pictured and described in this manual. Additionally, the placement of each label, on the Erchonia® device, is communicated.

This section is included to familiarize you with the components of the unit ensuring the remainder of this manual is clearly communicated.

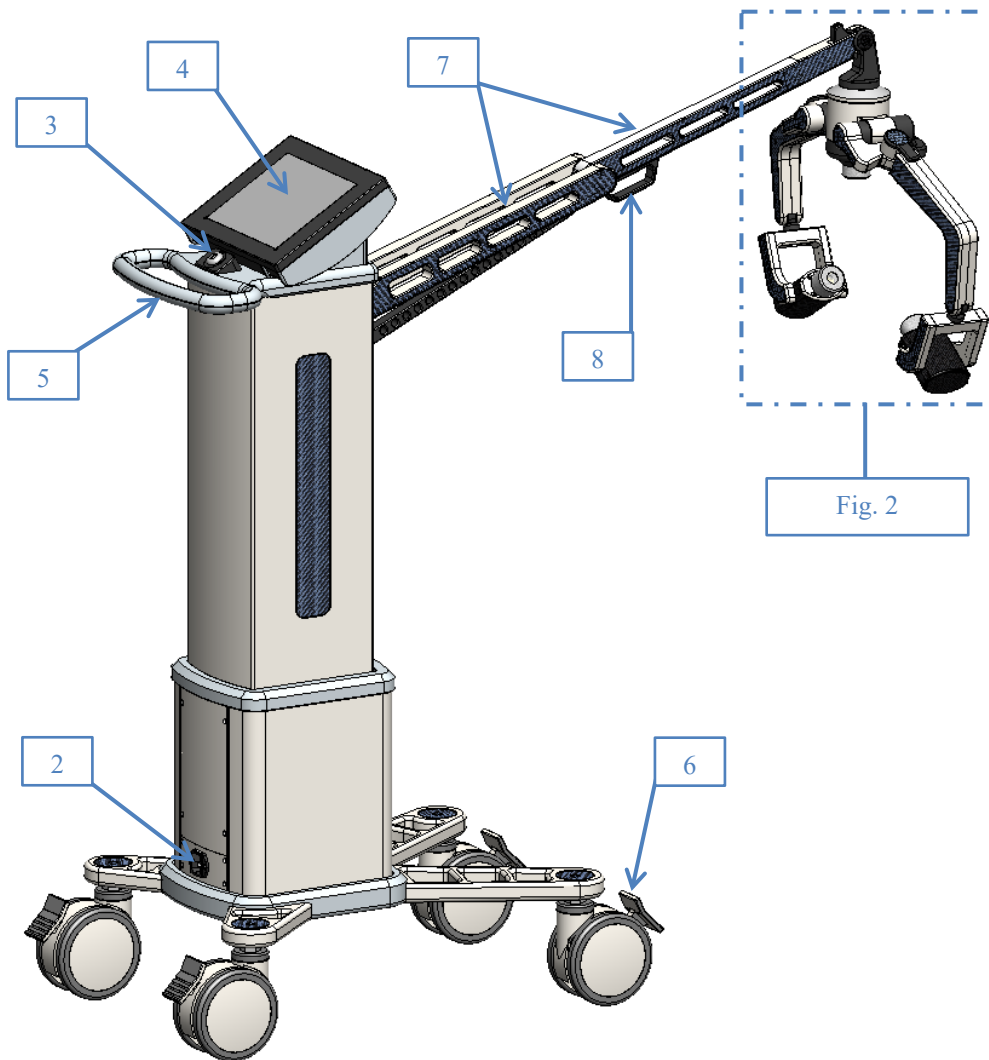

Fig. 1

1. Power Cord (not shown)
2. Power Inlet Module/ Fuse Holder
3. Power Safety Lockout Key
4. Touch Screen
5. Device Handle
6. Wheel Lock
7. Main Arm
8. Main Arm Handle

Fig. 1

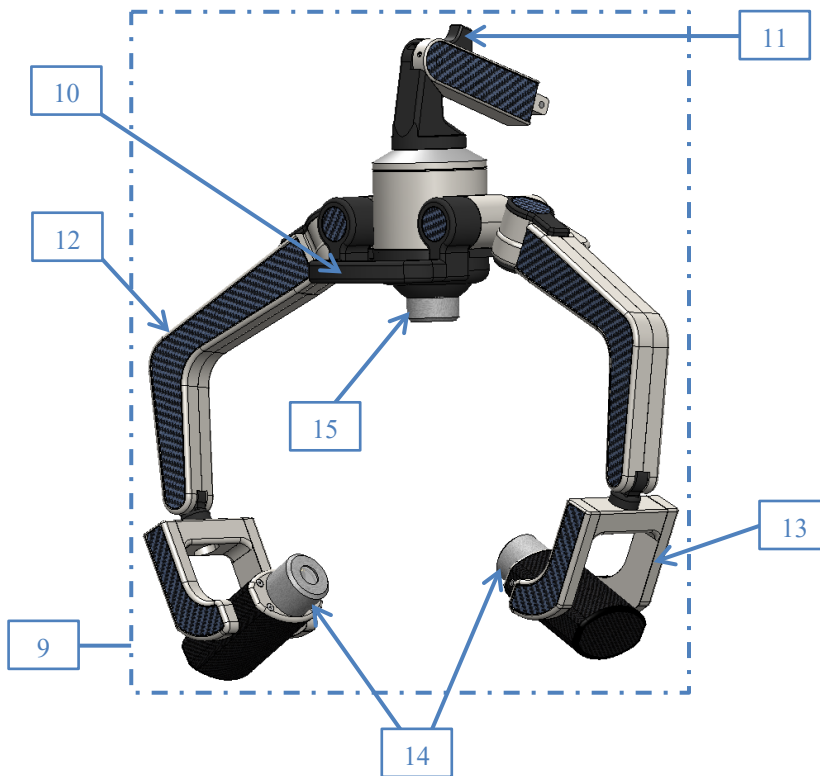

Fig. 2

Fig. 2

- 9. Laser Head Assembly
- 10. Laser Head Assembly Handle
- 11. Head Assembly Lever Lock
- 12. Upper Laser Arms
- 13. Lower Laser Arms
- 14. Left & Right Laser Heads
- 15. Center Laser Head
- 16. Protective Eyewear (not shown)
- 17. Height Extension Block w/ Locking Knob (not shown)

**DEVICE**

**Weight:** 81.6lbs / 37kg  
(Height x Depth x Width)

**Size-** Configuration 1 (main arm at full upright position): 62" x 49" x 36"/157.5cm x 124.5cm x 91.5cm

**Size-** Configuration 2 (main arm perpendicular to base): 45.5" x 57" x 36"/115.6cm x 144.8cm x 91.5cm

**Size-** Configuration 3 (main arm collapsed into device for Shipping): 45.5" x 25" x 18"/115.6cm x 63.5cm x 45.8cm

Power cord [1] connects the device to mains power supply.

**POWER CORD [1]**

The device contains a hospital grade flexible detachable power cord. Plug the power cord into the Power Inlet Module [2] prior to plugging the other end into a wall socket. The power cord does not contain any operator-serviceable components. If the power cord needs replacement, contact an Erchonia Corporation representative.

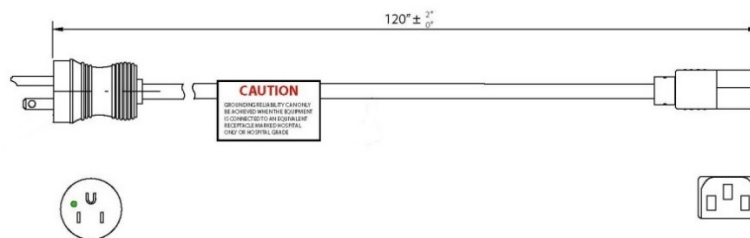

Fig. 3



**DO NOT** position the equipment so that it is difficult to disconnect the power cord.

### ***POWER INLET MODULE/FUSE HOLDER [2]***

The device contains a medical type filtered power entry module with double fuse holder. This is the location on the device where the power cord [1] is connected. **NOTE:** Make sure the power cord is connected into the device at this location prior to plugging into a wall socket. The Power Inlet module also contains a fuse holder. Replacing the fuses is the only service that can be conducted by the end user. To replace the fuses, refer to Maintenance Section of this manual.



### **WARNING-SHOCK HAZARD**

This device must only be connected to an electric supply main with protective earth. Make certain that the device is grounded by connecting only to a grounded 3 prong electrical socket conforming to the applicable national and local electrical codes. Use T2AH 250V Fuses only.

The device includes a transformer which converts 100 V - 240 V AC supply power to match the power output (i.e. 110 V or 240 V). Only a 3 prong power cord is required (Hospital Grade Only). Once the power cord connector is affixed to the power inlet, plug into the wall socket. Input: 100 VAC-240 VAC, 50-60 Hz, 1.5A-0.5A

### ***POWER SAFETY LOCKOUT KEY [3]***

The Power Safety Lockout Key is the visible portion of an internal locking mechanism located just below the touch screen [4] which provides an external key. Together they allow the user to turn the device ON or OFF. (“O” = OFF and “|” = ON) In the OFF position the device is locked. From the locked position the external key can be removed. This is a code-regulated feature installed to ensure no unauthorized use of the laser device. The device will not operate if the key is in the OFF position. Turning the key to the OFF position while the device is in operation will immediately shut down the device. The key switch failsafe system is designed to prevent the 110/240 voltage supplied from a wall socket to come into contact with the end user. The system uses two 2-amp fuses, which will only require replacement if there is an issue.

**NOTE:** Two keys are included with the Erchonia® FX-635. (Brass with nickel plating). The device requires one (1) key to operate; the key cannot be removed unless in the “O” OFF position. Store your spare key in a secure location in the event the original is misplaced. Make certain you fully insert the key into the key switch for use.

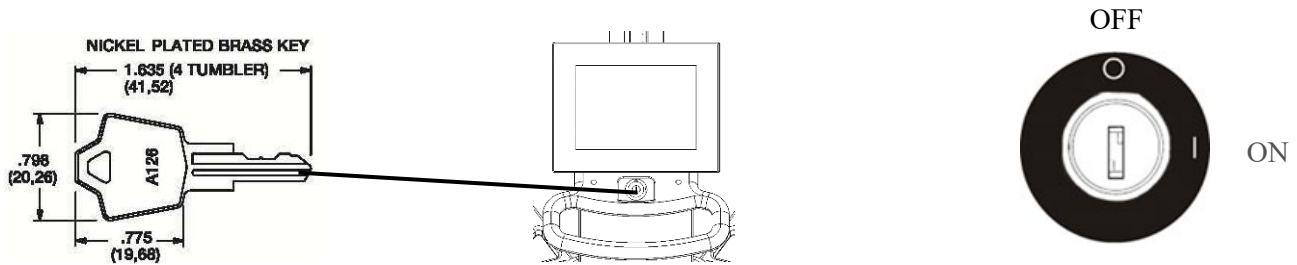

### ***TOUCH SCREEN [4]***

The touch screen functions as a display screen and an input panel, providing information to the user and a means to operate the device by touching the appropriate icon.



**CAUTION - DO NOT** use sharp objects such as a pencil point or ballpoint pen to operate the icons on the touch screen as damage may result. Avoid using abrasives (including paper towels) on the touch screen display window.

### ***DEVICE HANDLE [5]***

The Device Handle gives the user the ability to move the device for proper positioning to patient for accurate treatment location as well as move the device for storage or relocate to a different room. When the device is moved you must unlock the Wheel Locks [6]. **NOTE:** Hold the handle at all times during movement or relocation of the device.

### ***WHEEL LOCKS [6]***

The device includes four antistatic wheels that enable ease for maneuverability. Once the device is transported to the desired location the wheel locks should be engaged to eliminate excessive movement of the device.



#### **WARNING-TIPPING HAZARD**

When relocating the device, ensure that the main arm [7] is positioned fully seated into the device housing. Hold device handle [5] and take caution to ensure the device does not tip.



### ***MAIN ARM [7]***

The Main Arm serves to vertically position the Laser Head Assembly [9]. It is designed to adjust by intentional force from the end user. This allows the user to lower and raise the Laser Head Assembly for proper positioning to patient for accurate treatment distance.

### ***MAIN ARM HANDLE [8]***

Located on the Main Arm [7] is the Main Arm Handle. This handle is also used in conjunction with the Laser Head Assembly Handle [10] to be a pulling point for un-collapsing and collapsing the Main Arm.

### ***LASER HEAD ASSEMBLY [9]***

This three-head assembly located on the end of the Main Arm [7] accommodates the Laser Head Assembly Handle [10], Head Assembly Lever Lock [11], Upper Laser Arms [12], Lower Laser Arms [13], Left & Right Laser Heads [14] & Center Laser Head [15]. This assembly can be rotated 120 degrees for proper positioning to patient for accurate treatment.

### ***LASER HEAD ASSEMBLY HANDLE [10]***

The Laser Head Assembly Handle gives the user the ability to move the Main Arm [7] up/down and, used in conjunction with the Head Assembly Lever Lock [11], to angle the Laser Head Assembly [9] for proper positioning to patient for accurate treatment. This handle is also used in conjunction with the Main Arm Handle [8] to be a pulling point for un-collapsing and collapsing the Main Arm.

### ***HEAD ASSEMBLY LEVER LOCK [11]***

The Head Assembly Lever Lock is used in conjunction with the Laser Head Assembly Handle [10] and serves as the locking and unlocking lever for angling the Laser Head Assembly [9] for proper positioning to patient for accurate treatment.

### ***UPPER LASER ARMS [12]***

The Upper Laser Arms serve as a positioning support for the Left & Right Laser Heads [14]. It is designed to adjust by intentional force from the end user. This allows the user to lower and raise the Left & Right Laser Heads for proper positioning to patient for accurate treatment distance.

### ***LOWER LASER ARMS [13]***

The Lower Laser Arms serve as a positioning support for Left & Right Laser Heads [14]. It is designed to adjust by intentional force from the end user. This allows the end user to move the Left & Right Laser Heads in and out, as well as side to side for proper positioning to patient for accurate treatment distance.

### ***LEFT & RIGHT LASER HEADS [14]***

The Left & Right Laser Heads are located on the end of the Lower Laser Arms [13]. These accommodate the lens, laser diodes, motors, and their associated electronics. They are designed to adjust by intentional force from the end user; allowing the user to change the angle for proper positioning to patient for accurate treatment distance.

### ***CENTER LASER HEAD [15]***

The Center Laser Head is located just below the Laser Head Assembly Handle [10]. This accommodates the lens, laser diode, motor, and its associated electronics. It is designed to adjust by intentional force from the end user; allowing the user to change the angle for proper positioning to patient for accurate treatment distance.

### ***PROTECTIVE EYEWEAR [16]***

The Erchonia® FX635 is classified by the FDA/IEC as a Class 2 laser device. This designation represents a current standard for use in order to ensure the safety of the patient. A Class 2 laser is determined to have a chronic viewing hazard. Pointing the laser beam directly into the eye and maintaining it there for an extended period of time could prove to be damaging. To ensure there is no possible instance of residual effect, we have included a pair of specialty patient glasses for use by the patient during treatment. The safety glasses, sufficiently and effectively block the laser light spectrum at OD 2+ @ 635nm, OD 0.75 @ 405nm VLT60.

Height: 40 mm

Width: 145 mm

Length: 165 mm



The patient should always be correctly fitted with the safety glasses provided before turning on the laser and doing any treatments.

### ***HEIGHT EXTENSION BLOCK W/ LOCKING KNOB [17]***

The Height Extension Block w/ Locking Knob is an accessory that allows the device to treat at a higher height.

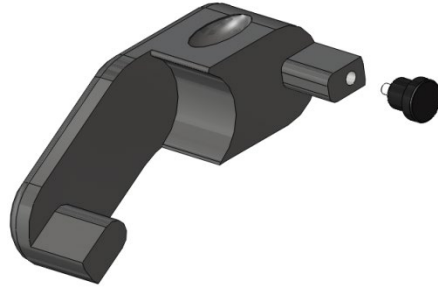

To install the Height Extension Block w/ Locking Knob onto the device, first unscrew and remove the locking knob from the extension block. Next, with the Main Arm fully extended and as high as possible, grab the Laser Head Assembly Handle and lift up while aligning the extension block two extrusions with arm cutouts as in the image below. Once aligned, fully insert extension block onto main arm until the extension block is flush with the main arm. Reinstall locking knob into extension block and screw securely in place.

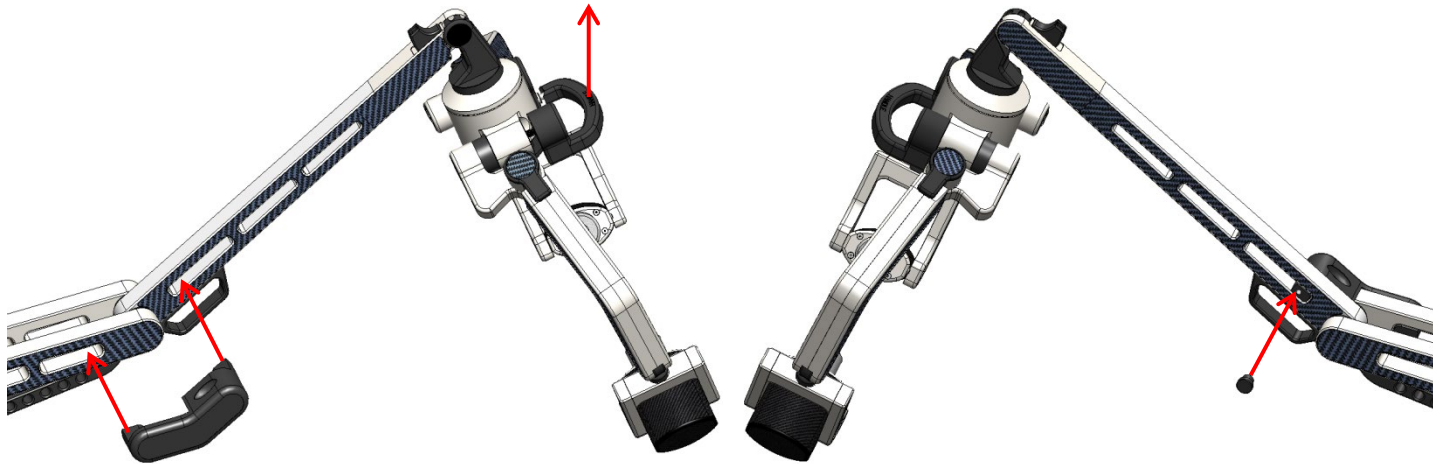

To remove the Height Extension Block w/ Locking Knob from the device, first ensure the Main Arm is fully extended and as high as possible. Next, unscrew and remove the locking knob from the extension block. After this grab the Laser Head Assembly Handle and lift slightly to take tension off of the extension block. Finally pull the extension block out of main arm cutouts and remove from the device.

## SECTION 3 SETUP & OPERATION

Now that you understand the basic features of the Erchonia® FX-635, it is important to understand how to use them when administering treatments. Below are the steps for setting the patient up for treatment.

### WHEEL LOCKS

The device includes four antistatic wheels that enable ease for maneuverability. Once the device is transported to the desired location, the wheel locks should be engaged to eliminate excessive movement of the device.



#### WARNING-TIPPING HAZARD

When relocating the device, ensure that the main arm [7] is positioned fully seated into the device housing. Hold device handle [5] and take caution to ensure the device does not tip.

### MAIN ARM & LASER HEAD ASSEMBLY OPERATION

The Main Arm is shipped in a collapsed position/shipping configuration (Image A, below). This position is designed **only** for shipping purposes and can be un-collapsed by intentional force from the end user.



**CAUTION** - When un-collapsing and collapsing the Main Arm follow instructions below, keeping your hands and fingers clear of pinch points.



To un-collapse the Main Arm from the device (**reference images below**), first lock all four wheels. Grab the Laser Head Assembly Handle (Image A, Step 1) with one hand (this is for support) and grab the Main Arm Handle (Image A, Step 2) with the other hand and simply pull out and up on the Main Arm Handle until the Main Arm is completely extended (Image B).

**Note:** Keep hands on Laser Head Assembly Handle and Main Arm Handle until arm is fully extended.

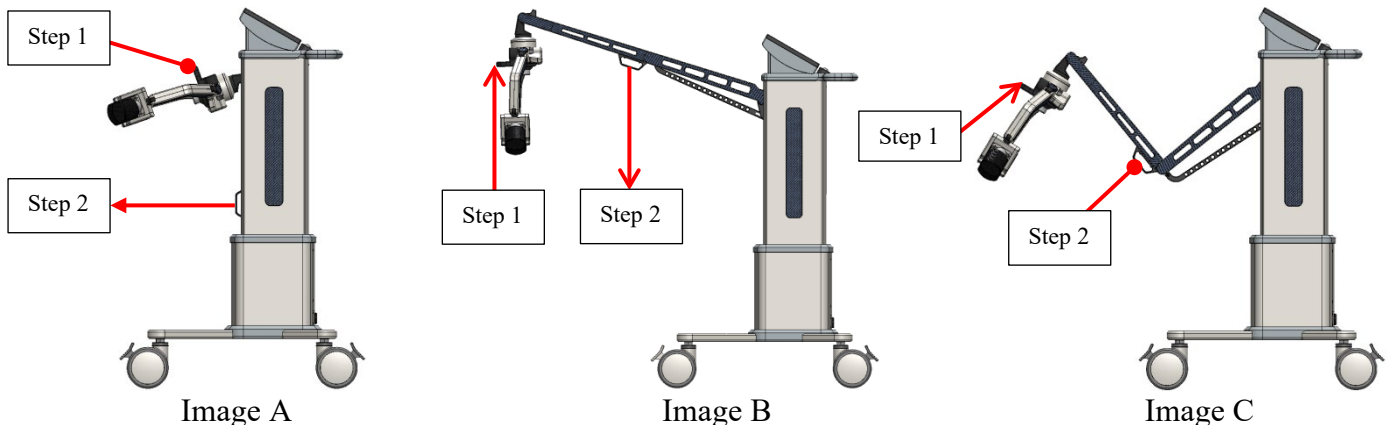

To collapse the Main Arm into the device (**reference images above**), first lock all four wheels. Grab the Laser Head Assembly Handle (Image B, Step 1) with one hand (this is for support) and grab the Main Arm Handle (Image B, Step 2) with the other hand and simply pull down with the Main Arm Handle and push up with the Laser Head Assembly Handle until the Main Arm is in a half-collapsed position (Image C). Once Main Arm is in a half-collapsed position (Image C), push in and down on the Laser Head Assembly Handle (Image C, Step 1) and now use your other hand on the Main Arm Handle for support only (Image C, Step 2). Continue until the Main Arm is fully seated into the device housing (Image A).

**CAUTION: PINCH HAZARD**

Keep hands and fingers clear from areas indicated.

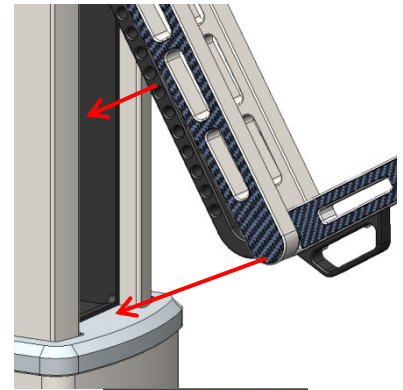
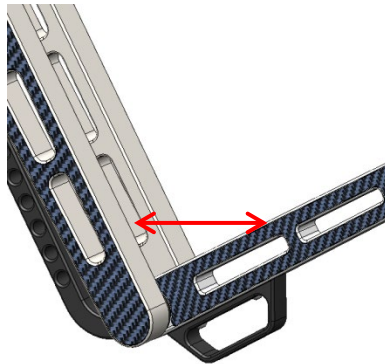
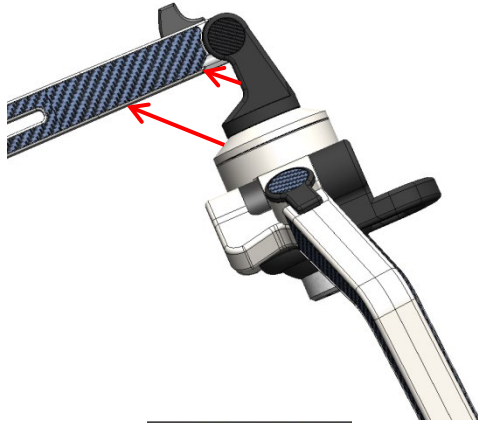

- 1) **Adjust the Laser Head Assembly height for proper positioning to patient for accurate treatment** Place patient in treatment position under the Laser Head Assembly. Grab the Laser Head Assembly Handle and raise or lower the Main Arm to the optimal height for treating patient.

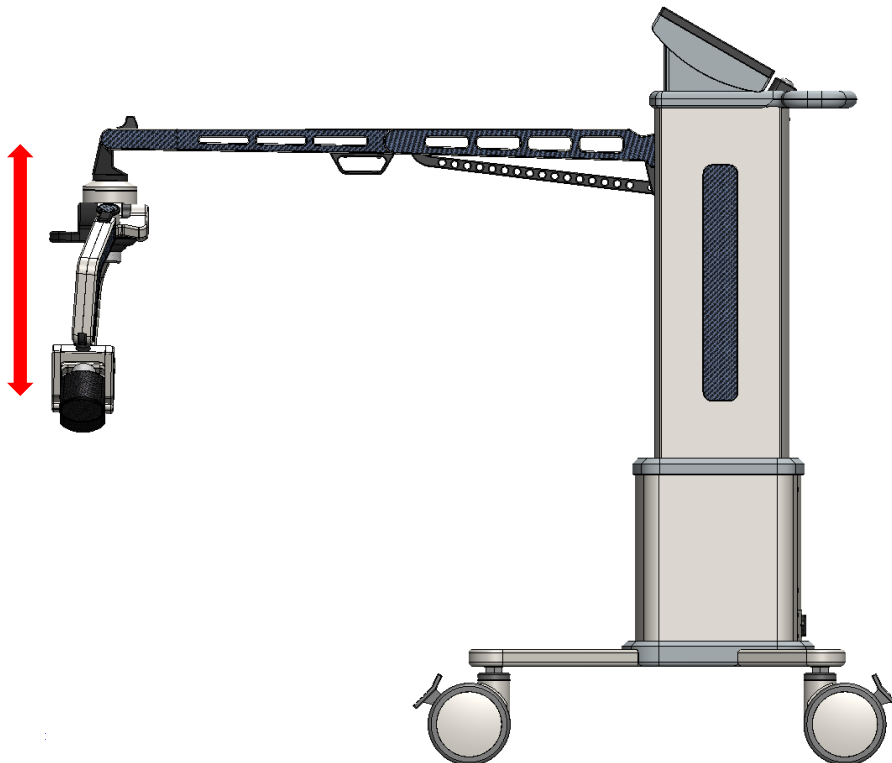



**CAUTION** - When adjusting the Laser Head Assembly angle follow instructions below, keeping your hands and fingers clear of pinch points.



- 2) Adjust the Laser Head Assembly angle for proper positioning to patient for accurate treatment. First, grasp the Laser Head Assembly Handle and pull up while pushing the Head Assembly Lever Lock back; continue to hold Head Assembly Lever Lock in the back position and hold the Laser Head Assembly Handle. Next, move the Laser Head Assembly Handle to the proper angle and then release the Head Assembly Lever Lock and move the Laser Head Assembly Handle up or down until you feel the Head Assembly Lever Lock engage.

**Note:** There are 3 angle lock positions.

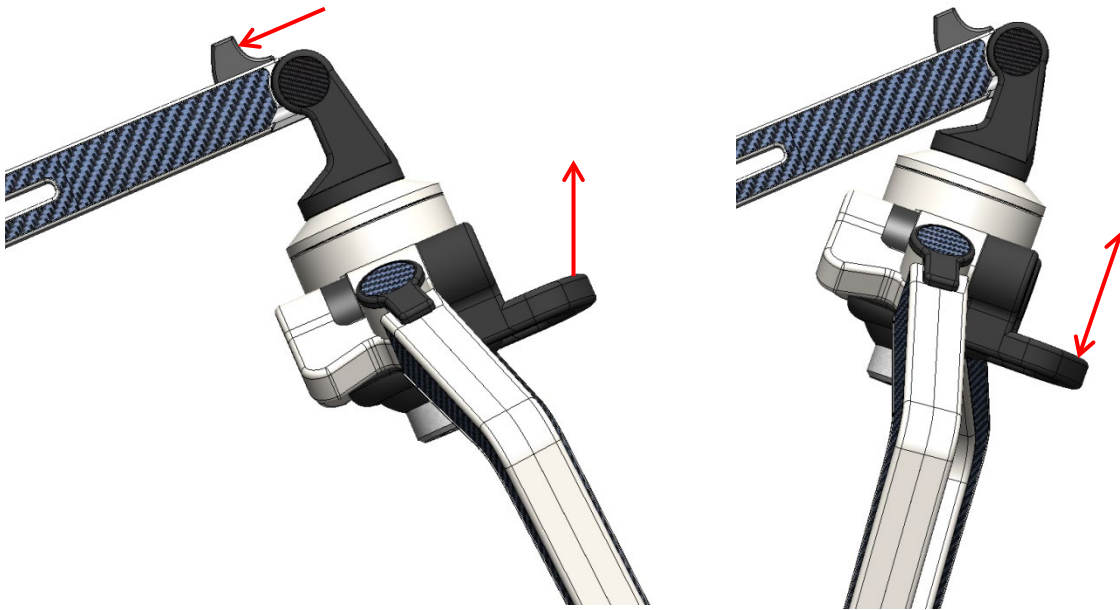

- 3) Adjust the Laser Head Assembly arms and laser heads for proper positioning to patient for accurate treatment. Grab the Laser Head Assembly Handle and rotate the Laser Head Assembly left or right. Grab the Upper Laser Arms and move up or down, left or right. Grab the Lower Arms and rotate left or right, or move up or down. Grab the Left & Right Laser Heads and move up or down. Grab the Center Laser Head and move back or forth.

**Note:** When adjusting the lasers try not to touch the lens: making lens dirty.

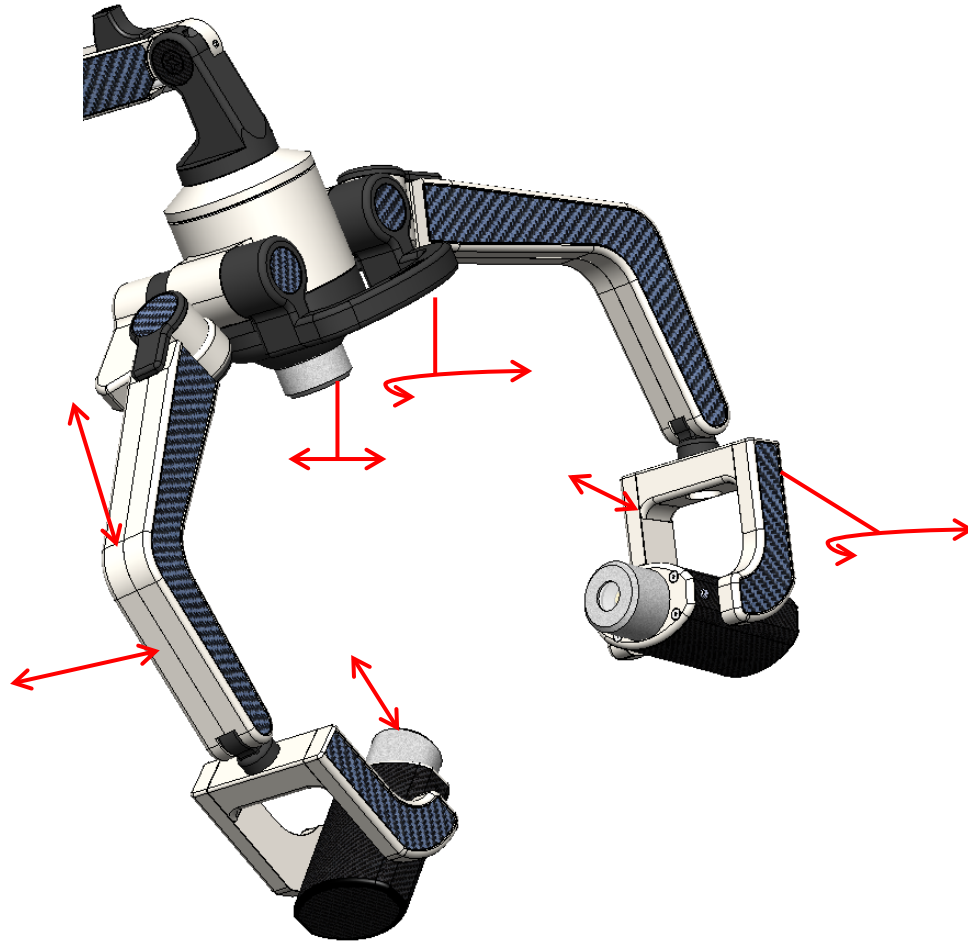

## POWERING UP THE DEVICE

1. Plug the Power Cord into device Power Inlet.
2. Plug the other end of Power Cord into a wall socket.
3. Turn the device ON by placing one of the keys into the key lock and turning it clockwise to the ON “I” position.

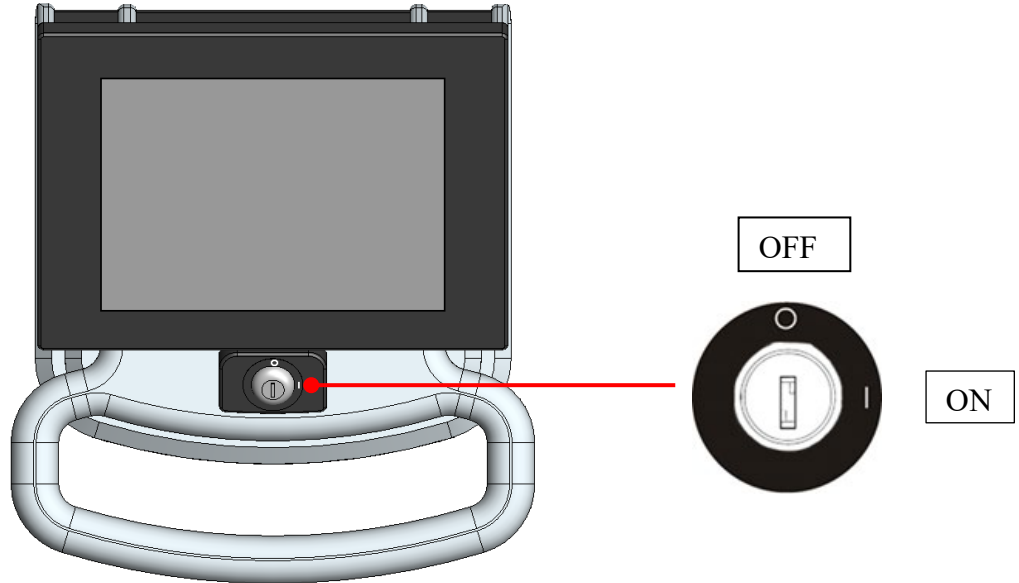

- a. Once the key lock is turned to the ON position, a green LED will turn ON in the top left corner of Touch Screen label.
- b. After approximately 15 seconds the device will beep and the Touchscreen will display the **Loading Screen**.
- c. After approximately 20 seconds the screen will change to the **Home Screen**.

### Loading Screen

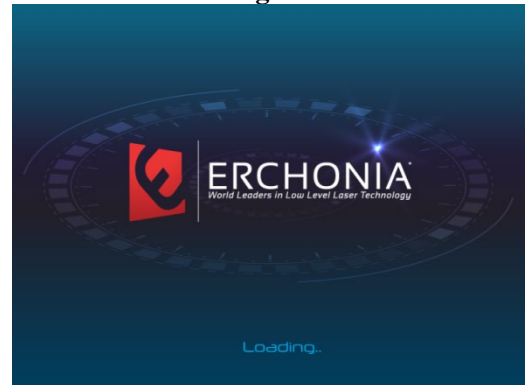

### Home Screen



On the **Home Screen** there are three options:

- a. To access the **Quick Program** and the **Preset Protocols**, touch the “Quick & Preset Protocols” icon.
- b. To access the **User Protocols**, touch the “User Protocols” icon.
- c. To access the **Credit & Device Information Screen**, touch the “Erchonia” icon.

## PRESET PROTOCOLS

There are 7 preset protocols implemented into the device software, preset for particular pain indications:

- Head and Cerebellum
- Neck
- Shoulder
- Elbow
- Wrist/Hand
- Low Back
- Knee
- Ankle/Foot
- Heel
- Post-Op
- Pre-Op

1. To access the preset protocols, touch the “Quick & Preset Protocols” icon located on the **Home Screen**. The screen will change to the **Quick & Preset Protocols Menu Screen**.

2. To access the preset protocol, touch the specific “Preset Protocol” icon. The screen will change to the selected **Preset Protocol Screen**.

3. Touch “**START**” icon to begin the non-invasive procedure. Once you start the procedure you will observe the following:

- three visible red laser diodes turn on rotating clockwise;
- the time remaining window starts counting down;
- the “**START**” icon will flash displaying “**STOP**”,
- the “**Credits Rem.**” icon will deduct by one.

**Note:** (1) One credit will be deducted every time the “**START**” icon is touched. Do not use the “**STOP**” icon as a pause.

Home Screen



Quick & Preset Protocols Menu Screen

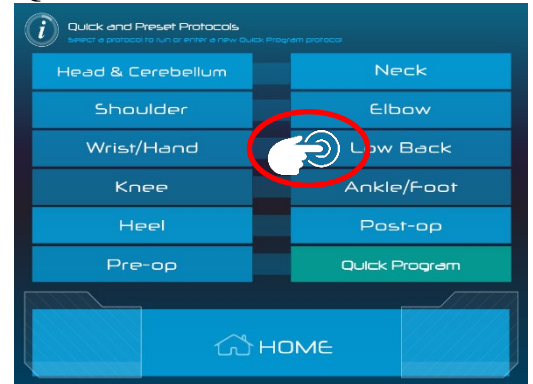

(Example) Low Back Screen

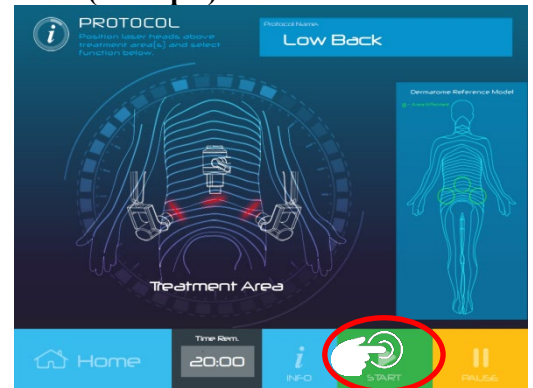

4. To pause, touch the **“PAUSE”** icon. When the procedure is paused, you will observe the following:
  - three red laser diodes and rotation turn off;
  - the time remaining counter pauses;
  - the **“PAUSE”** icon will flash, displaying **“RESUME”**;
5. To resume with the procedure, touch the flashing **“RESUME”** icon.
6. Once the **“Time Rem.”** display reaches 0:00 the lasers will power off, you will hear three audio “beeps” (if the Protocol Audio Beep option is turned on), the time will reset.
7. Touch the **“HOME”** icon to return to the **Home Screen** and turn the device OFF by turning the key counterclockwise to the OFF **“O”** position.

**Note:** You can touch **“STOP”** icon, turn the key to the OFF position or unplug the device from the power outlet at any time to power off the device.

**Note:** The Pre-Op and Post-Op protocols give you the option to turn off individual lasers by simply touching the **“ON/OFF Icons”** located next to each laser head.

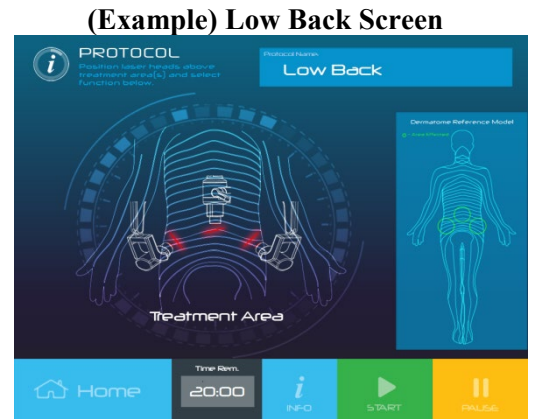

**ON Icon**



**OFF Icon**



# USER PROTOCOLS FOR OTHER PAIN INDICATIONS

User Protocols allows the user to program up to 40 additional pain indications. Protocol programming consists of: the protocol name, the protocol laser frequency/Hz & the protocol treatment time.

1. To access the user protocols, touch the “User Protocols” icon located on the **Home Screen**. The screen will change to the **User Protocols Menu Screen**.

Home Screen



2. To access the user protocol, touch one of the “Blue Icons”. The screen will change to the **User Protocol Screen**.

**Note:** Pressing the “Page>” or “<Page” icons will display additional user protocols.

User Protocols Menu Screen

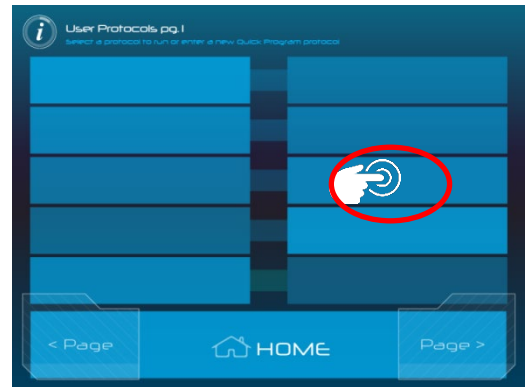

3. To program a protocol, touch the “SETTINGS” icon. The screen will change to the **User Protocol Settings Screen**.

User Protocol Screen

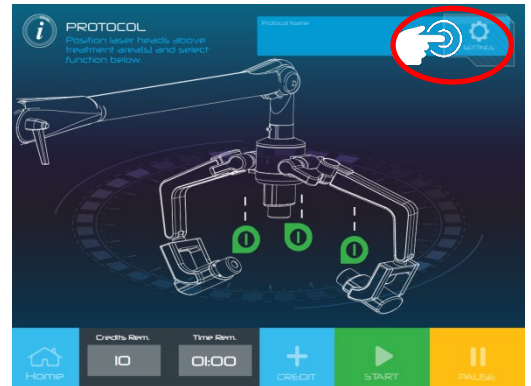

### User Protocol Settings Screen

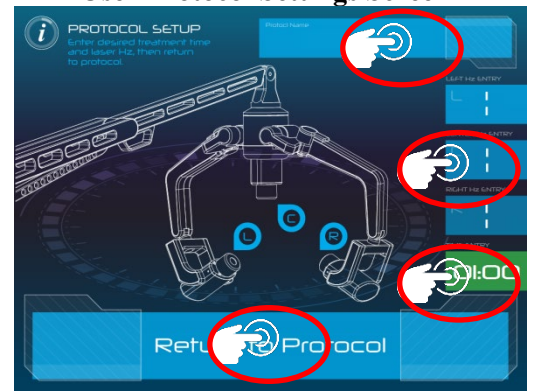

### Protocol Name Entry Screen

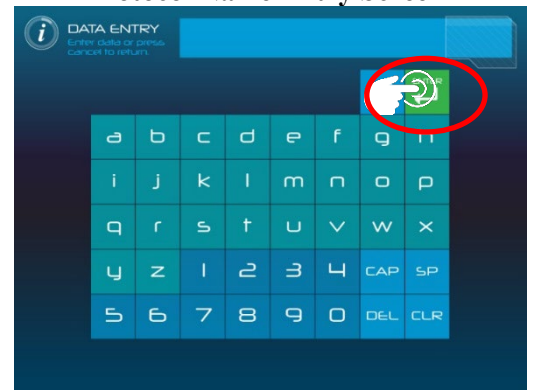

### Numeric Keypad Screen

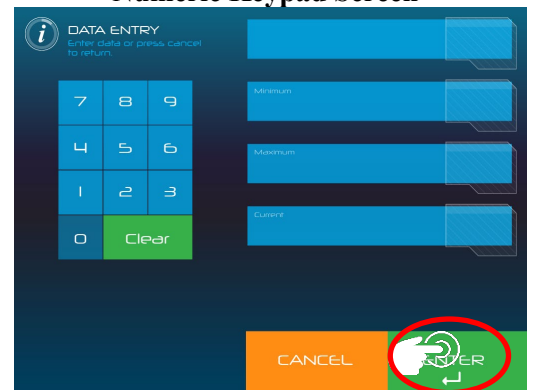

### User Protocol Screen

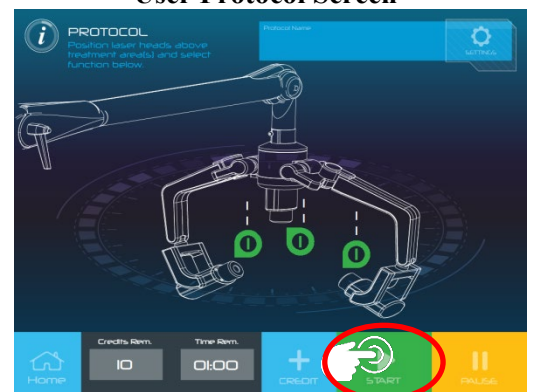

4. To program a protocol name, touch the “Protocol Name Entry” icon. The screen will change to the **Protocol Name Entry Screen**.
5. Enter the protocol name (up to 20 characters) and touch the “ENTER” icon. The screen will change back to the **User Protocol Settings Screen**.
6. To program a frequency/Hz, touch one of the “Hz ENTRY” icons. The screen will change to the **Numeric Keypad Screen**.
7. Enter the Hz (1 – 100,000) for Hz1 and touch the “ENTER” icon. **Note:** The screen will not change as Hz2 still needs to be entered.
8. Enter the Hz (1 – 100,000) for Hz2 and touch the “ENTER” icon. The screen will change back to the **User Protocol Settings Screen**. **Note:** Steps 6 – 8 can be repeated for all lasers, via: “LEFT Hz ENTRY”, “CENTER Hz ENTRY” & “RIGHT Hz ENTRY”.
9. To program a protocol time, touch the “TIME ENTRY” icon. The screen will change to the **Numeric Keypad Screen**.
10. Enter the time in minutes (1 – 20 minutes) and touch the “ENTER” icon. The screen will change to the **User Protocol Settings Screen**.
11. To return to the user protocol, touch the “Return to Protocol” icon. The screen will change to the **User Protocol Screen**.

12. Touch “**START**” icon to begin the non-invasive procedure. Once you start the procedure you will observe the following:
  - three visible red laser diodes turn on rotating clockwise;
  - the time remaining window starts counting down;
  - the “**START**” icon will flash displaying “**STOP**”;
  - the “**Credits Rem.**” icon will deduct by one.

**Note:** (1) One credit will be deducted every time the “**START**” icon is touched. Do not use the “**STOP**” icon as a pause.

13. To pause, touch the “**PAUSE**” icon. When the procedure is paused, you will observe the following:
- three red laser diodes and rotation turn off;
  - the time remaining counter pauses;
  - the “**PAUSE**” icon will flash, displaying “**RESUME**”;
14. To resume with the procedure, touch the flashing “**RESUME**” icon.
15. Once the “**Time Rem.**” display reaches 0:00 the lasers will power off, you will hear three audio “beeps” (if the Protocol Audio Beep option is turned on), the time will reset.
16. Touch the “**HOME**” icon to return to the **Home Screen** and turn the device OFF by turning the key counterclockwise to the OFF “**O**” position.

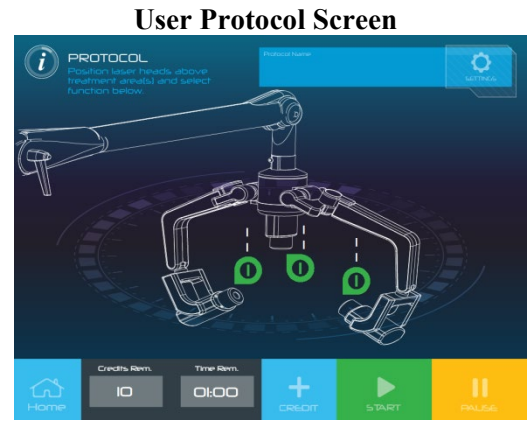

**Note:** You can touch “**STOP**” icon, turn the key to the OFF position or unplug the device from the power outlet at any time to power off the device.

**Note:** The user protocols give you the option to turn off individual lasers by simply touching the “ON/OFF Icons” located next to each laser head.



# QUICK PROGRAM FOR OTHER PAIN INDICATIONS

Quick Program allows the user to program an additional pain indication. Protocol programming consist of: the protocol laser frequency/Hz & the protocol treatment time.

1. To access the quick program, touch the “Quick & Preset Protocols” icon located on the **Home Screen**. The screen will change to the **Quick & Preset Protocols Menu Screen**.

Home Screen

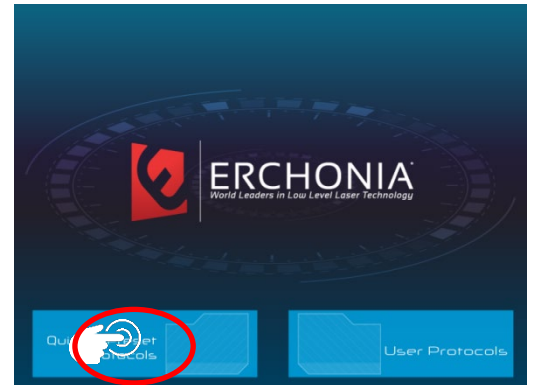

2. To access the quick program, touch the “Quick Program” icon. The screen will change to the **Quick Program Screen**.

Quick & Preset Protocols Menu Screen

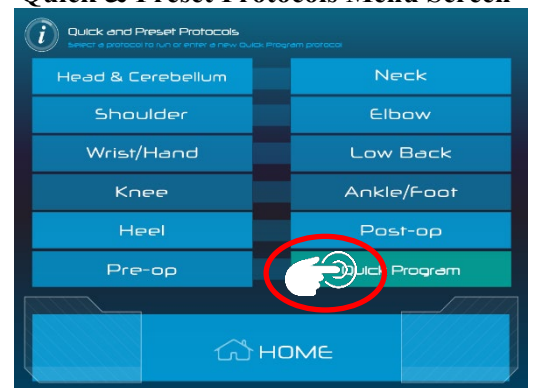

3. To program the protocol, touch the “SETTINGS” icon. The screen will change to the **Quick Program Settings Screen**.

Quick Program Screen

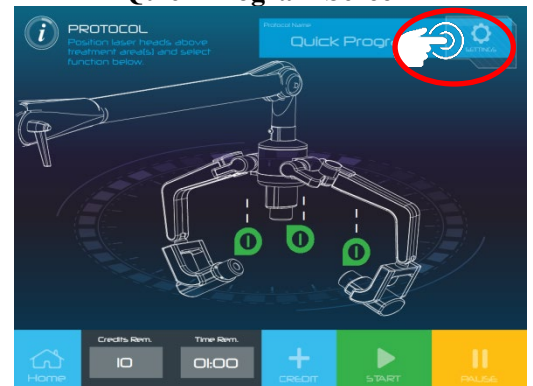

### Quick Program Settings Screen

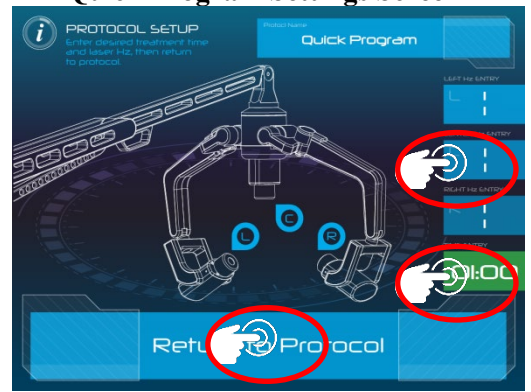

4. To program a frequency/Hz, touch one of the “Hz ENTRY” icons. The screen will change to the **Numeric Keypad Screen**.
5. Enter the Hz (1 – 100,000) for Hz1 and touch the “ENTER” icon. **Note:** The screen will not change as Hz2 still needs to be entered.
6. Enter the Hz (1 – 100,000) for Hz2 and touch the “ENTER” icon. The screen will change back to the **User Protocol Settings Screen**. **Note:** Steps 6 – 8 can be repeated for all lasers, via: “LEFT Hz ENTRY”, “CENTER Hz ENTRY” & “RIGHT Hz ENTRY”.
7. To program the protocol time, touch the “TIME ENTRY” icon. The screen will change to the **Numeric Keypad Screen**.
8. Enter the time in minutes (1 – 20 minutes) and touch the “ENTER” icon. The screen will change to the **User Protocol Settings Screen**.
9. To return to the user protocol, touch the “Return to Protocol” icon. The screen will change to the **User Protocol Screen**.

### Protocol Name Entry Screen

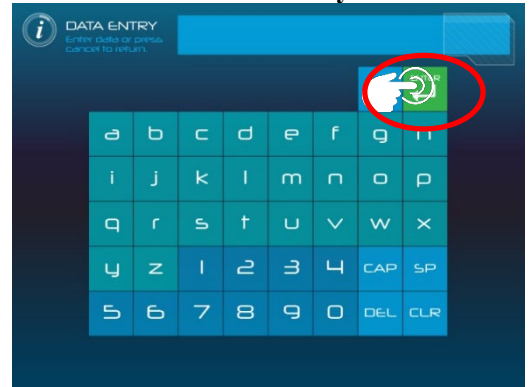

### Numeric Keypad Screen

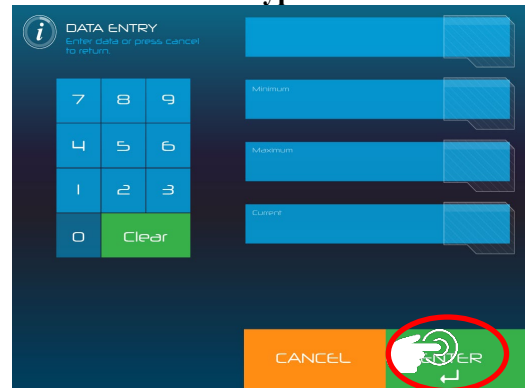

### Quick Program Screen

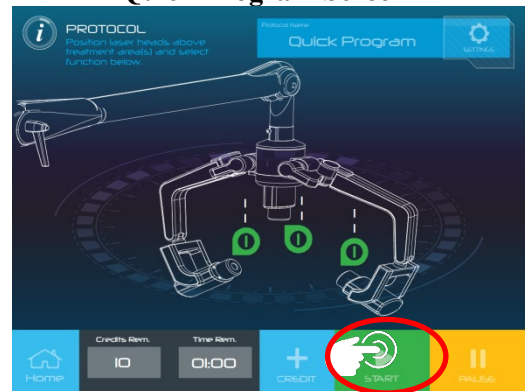

10. Touch “**START**” icon to begin the non-invasive procedure. Once you start the procedure you will observe the following:

- three visible red laser diodes turn on rotating clockwise;
- the time remaining window starts counting down;
- the “**START**” icon will flash displaying “**STOP**”,
- the “**Credits Rem.**” icon will deduct by one.

**Note:** (1) One credit will be deducted every time the “**START**” icon is touched. Do not use the “**STOP**” icon as a pause.

11. To pause, touch the “**PAUSE**” icon. When the procedure is paused, you will observe the following:

- three red laser diodes and rotation turn off;
- the time remaining counter pauses;
- the “**PAUSE**” icon will flash, displaying “**RESUME**”;

12. To resume with the procedure, touch the flashing “**RESUME**” icon.

13. Once the “**Time Rem.**” display reaches 0:00 the lasers will power off, you will hear three audio “beeps” (if the Protocol Audio Beep option is turned on), the time will reset.

14. Touch the “**HOME**” icon to return to the **Home Screen** and turn the device OFF by turning the key counterclockwise to the OFF “**O**” position.

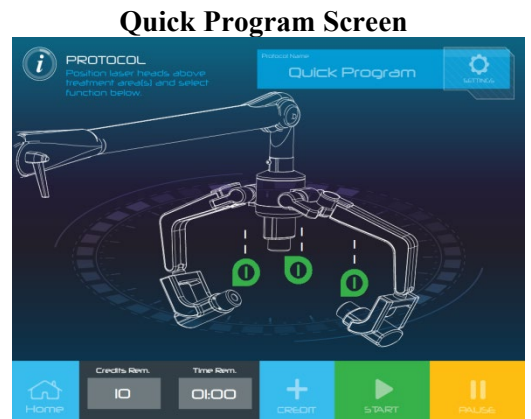

**Note:** You can touch “**STOP**” icon, turn the key to the OFF position or unplug the device from the power outlet at any time to power off the device.

**Note:** The quick program gives you the option to turn off individual lasers by simply touching the “**ON/OFF Icons**” located next to each laser head.

**ON Icon**



**OFF Icon**



# CREDIT & DEVICE INFORMATION SCREEN

To access the **Credit & Device Information Screen**, touch either the “Erchonia” icon on the **Home Screen** or touch the “CREDIT” icon on any of the **Protocol Screens**. The **Credit & Device Information Screen** displays:

- The firmware and software of device
- The device computer date
- The serial number of device
- The total treatments of device
- The entry icon for adding credits
- The display of credits remaining
- The entry icon for credit unlock code
- The unlock icon for applying unlock code
- The protocol audio beep function

The “Protocol Audio Beep” feature is used to turn ON or OFF the audio beep while a protocol is running a treatment as well as the audio beep at the end of a protocol treatment. The icon will display “On” if the audio beep state is set ON, or “Off” if the audio beep state is set OFF. To change the state of the audio beep (OFF or ON), simply press the “Protocol Audio Beep” icon.

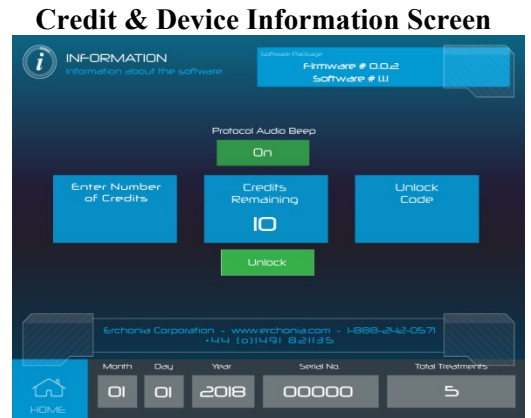

## HOW DO CREDITS WORK?

Credits are required for the FX635 laser to operate the non-invasive procedures. The FX635 software for this device is developed to deduct one credit every time the “**START**” icon is touched. The Protocol Screens and the Credit & Information Screen allow you to view the amount of remaining credits on the device at any time. To ensure that your device is operational at all times, contact Erchonia’s Sales Support before the credits remaining reaches 0. Once the credits remaining reaches 0, the device will no longer operate.

The following icons will display on screens when all credits have expired and the device will no longer operate the non-invasive procedures.



“NO CREDITS REMAINING” flashing blue icon will display on **Home Screen**

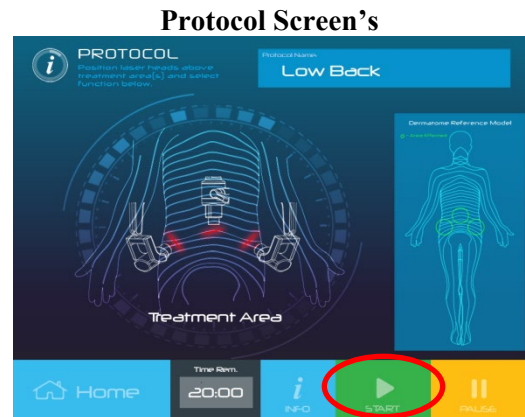

“START” icon changes to “NO CREDITS REMAINING” flashing blue icon and “Credits Rem.” will display a value of 0 on **Protocol Screen’s**

# TO ADD CREDITS

## Credit & Device Information Screen

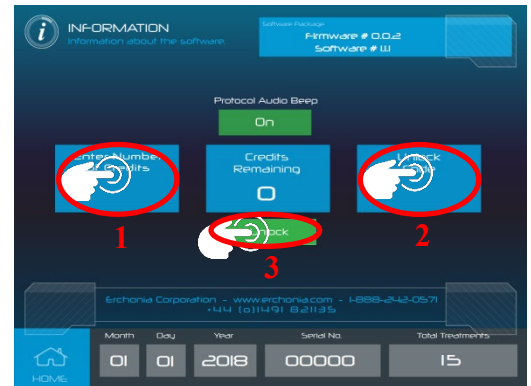

## Numeric Keypad Screen

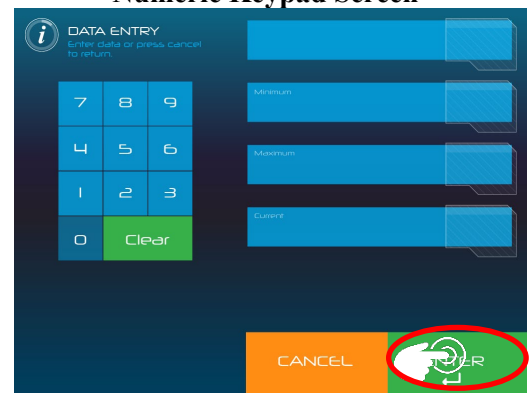

1. Contact Erchonia Sales Support. You will need to provide your device serial number and the date displayed on the device's **Credit & Device Information Screen**.
2. Touch the “Enter Number of Credits” icon. The screen will change to the **Numeric Keypad Screen**.
3. Enter the number of credits purchased then touch the “ENTER” icon to accept. The screen will change back to the **Credit & Device Information Screen**.
4. Touch the “Unlock Code” icon. The screen will change to the **Numeric Keypad Screen**.
5. Enter the 8 digit unlock code given to you by the Erchonia representative then touch the “ENTER” icon. The screen will change back to the **Credit & Device Information Screen**.
6. Touch the “Unlock” icon. If the 8 digit unlock code and number of credits is entered correctly a “Unlocked” icon will display beneath the “Unlock Code” icon and the “Unlock” icon will no longer display.

**Note:** If an improper code is entered a “Code Failure” icon will display beneath the “Enter Number of Credits” icon.

## (Example) Proper Code Entered

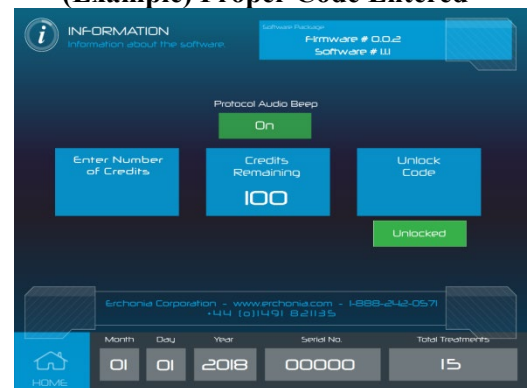

## (Example) Improper Code Entered



# LABELS

The device is manufactured in accordance to the Good Manufacturing Procedures set forth by the FDA, ISO Standards (International) and CE (Certified European) standards and testing results per Article 9, the device is a Class I Shock Protection and a Class II Medical device. Each of these governing agencies requires specific labeling. All required labels affixed according to the relevant codes. Each label is pictured and described in this section. Additionally, the placement of each label, on the device, is communicated.

The following diagram shows the compliance label and serial number label with their placement. Integrated into the compliance label is the electrical input label containing Volts, Amps and fuse specifications. The large black background label is this primary label and is compliant to FDA and ISO standards; the image captures the FDA code regulated classifications and International criteria.

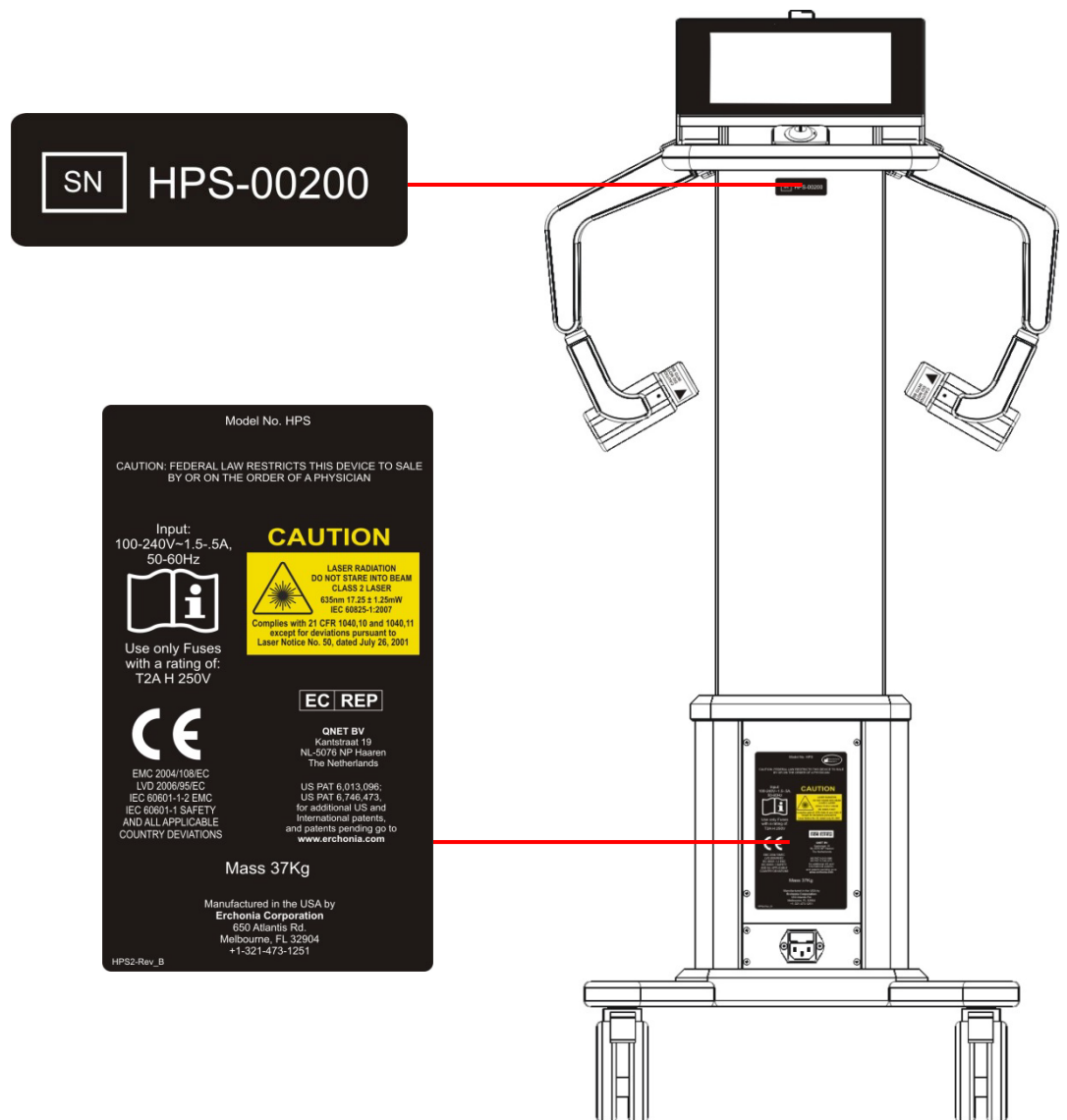

The following diagram shows the location of the pinch point labels. On the opposite side of arm there are pinch point labels in the same location.

When transporting the device (example: from one room to another) ensure that the main arm is collapsed into the device and take caution to ensure the device does not tip.

The “Do not Push” label is located on each side of the touch screen to inform end user not to push in this direction which could cause the device to tip over.

**Note:** Reference “Main Arm” in “Product Overview” section for further detail of pinch points and collapsing the main arm.

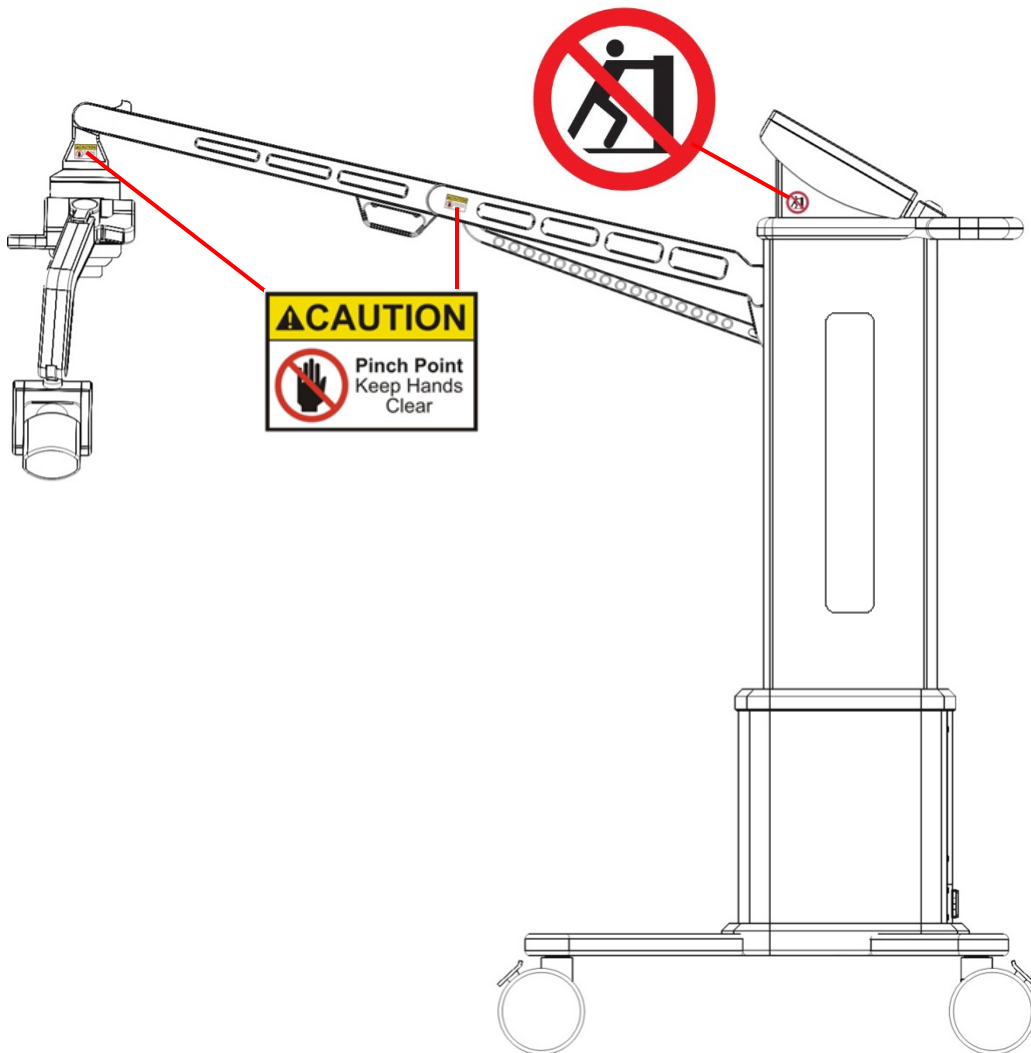

The following diagram shows each of the laser diodes (3) have a label affixed that show the direction of the laser beam output and the additional locations of the pinch point labels.

**Note:** Reference “Main Arm” in “Product Overview” section for further detail of pinch points and un-collapsing the main arm.

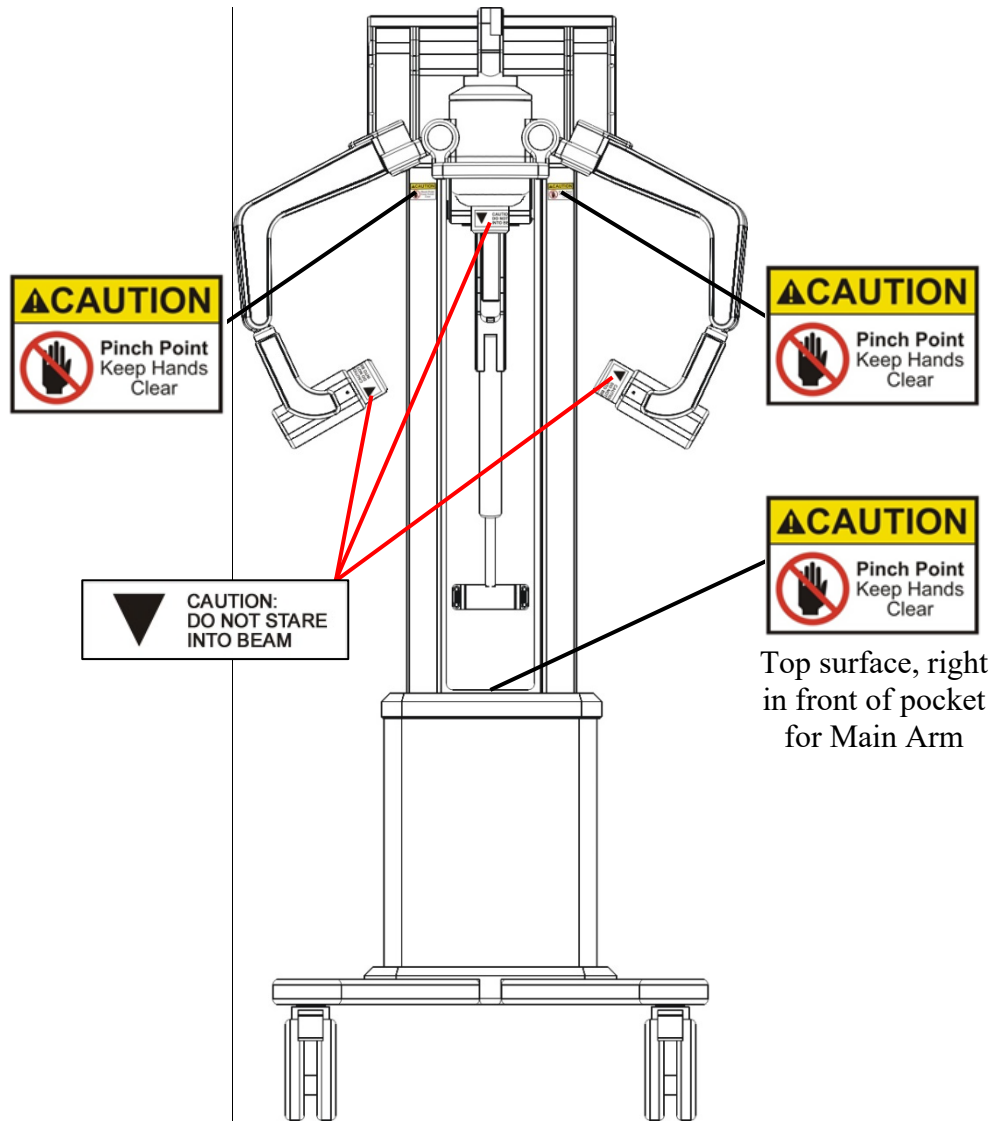

## SECTION 4 PROFESSIONAL USE INSTRUCTIONS

### APPLICATION/ADMINISTRATION

*This section defines instructions for the application of the laser energy and established protocols.*

The Erchonia Laser device is intended for use by health care professionals as an adjunct use for the temporary relief of pain. The treatment protocols that are hardcoded into the device has been developed in conjunction with Medical Doctors, Erchonia Corporation Researchers and IRB advisors. Medical professional in receipt of this device are to use the preset protocol as their medical training and experience dictate.

**Rx Only - IN THE US, FEDERAL LAW RESTRICTS THIS DEVICE TO SALE BY OR ON THE ORDER OF A PHYSICIAN**

### HEEL PROTOCOL

- There are two laser procedure administrations per week for a total of 6 administrations.
- Each laser procedure administration is scheduled 48 to 72 hours apart.
- Each laser procedure administration lasts 10 minutes.

The protocol is as follows:

1. The patient enters the procedure administration room and is seated on a chair with the afflicted foot/heel elevated or lays face up on a table.
2. The administrator positions one of each of the 3 laser lights between 3 and 4 inches away from, but directed toward,
  - a) the left laser on the myofascial junction of the heel;
  - b) the center laser on the top of the foot (dorsal aspect);
  - c) the right laser on the plantar aspect of the heel.
3. The Erchonia Laser is activated.
4. The laser diodes laze each of these 3 areas for 10 minutes simultaneously.
5. The patient rises and leaves the procedure administration room.

## **LOW BACK PROTOCOL**

- There are two laser procedure administrations per week for a total of 8 administrations.
- Each laser procedure administration is scheduled 72 to 96 hours apart.
- Each laser procedure administration lasts 20 minutes.

The protocol is as follows:

1. The patient enters the procedure administration room and lays face down on a table.
2. The administrator positions one of each of the 3 laser lights between 3 and 4 inches away from, but directed toward,
  - a) the left laser on the hip flexor;
  - b) the center laser on the lumbar spine;
  - c) the right laser on the other hip flexor.
3. The Erchonia Laser is activated.
4. The laser diodes laze each of these 3 areas for 20 minutes simultaneously.
5. The patient rises and leaves the procedure administration room.

## **HEAD AND CEREBELLUM PROTOCOL**

The Head and Cerebellum Protocol is to be used in conjunction with the Neck and/or Shoulder Protocol. The protocol is to be administered in the following order:

1. Head and Cerebellum Protocol (Step 1)
2. Neck and/or Shoulder Protocol (Step 2)

- Head and Cerebellum procedure administration lasts 5 minutes.

The protocol is as follows:

1. The patient enters the procedure administration room and is seated on a chair.
2. The administrator positions one of each of the 3 laser lights between 3 and 4 inches away from, but directed toward,
  - a) the left laser on the left cerebellum;
  - b) the center laser on the top of head;
  - c) the right laser on the right cerebellum.
3. The Erchonia Laser is activated.
4. The laser diodes laze each of these 3 areas for 5 minutes simultaneously.
5. The administrator proceeds to administer the Neck and/or Shoulder Protocol (Step 2).

## **NECK PROTOCOL**

The protocol is as follows:

1. The patient enters the procedure administration room and lays face down on a table.
2. The administrator positions one of each of the 3 laser lights between 3 and 4 inches away from, but directed toward,
  - a) the left laser on the left upper trapezius
  - b) the center laser on the cervical spine
  - c) the right laser on the right upper trapezius.
3. The Erchonia Laser is activated.
4. The laser diodes laze each of these 3 areas for 10 minutes simultaneously.
5. The patient rises and leaves the procedure administration room.

## **SHOULDER PROTOCOL**

The protocol is as follows:

1. The patient enters the procedure administration room and is either seated on a chair or lays face down on a table.
2. The administrator positions one of each of the 3 laser lights between 3 and 4 inches away from, but directed toward,
  - a) the left laser on the anterior Deltoid
  - b) the center laser on the medial (top) Deltoid
  - c) the right laser on the posterior Deltoid
3. The Erchonia Laser is activated.
4. The laser diodes laze each of these 3 areas for 10 minutes simultaneously.
5. The patient rises and leaves the procedure administration room.

## **ELBOW PROTOCOL**

The protocol is as follows:

1. The patient enters the procedure administration room and lays on a table, of the opposite side of the afflicted elbow.
2. The administrator positions one of each of the 3 laser lights between 3 and 4 inches away from, but directed toward,
  - a. the left laser on the medial epicondyle
  - b. the center laser on the top of elbow (anconeus)
  - c. the right laser on the lateral epicondyle
3. The Erchonia Laser is activated.
4. The laser diodes laze each of these 3 areas for 10 minutes simultaneously.
5. The patient rises and leaves the procedure administration room.

## **WRIST/HAND PROTOCOL**

The protocol is as follows:

1. The patient enters the procedure administration room and is seated on chair or table.
2. The administrator positions one of each of the 3 laser lights between 3 and 4 inches away from, but directed toward,
  - a. the left laser on the ulna side of wrist
  - b. the center laser on the back of the hand (dorsal)
  - c. the right laser on the radial side of wrist
3. The Erchonia Laser is activated.
4. The laser diodes laze each of these 3 areas for 10 minutes simultaneously.
5. The patient rises and leaves the procedure administration room.

## **KNEE PROTOCOL**

The protocol is as follows:

1. The patient enters the procedure administration room and lays face up on a table.
2. The administrator positions one of each of the 3 laser lights between 3 and 4 inches away from, but directed toward,
  - a. the left laser on the medial knee
  - b. the center laser on the anterior (front) of knee
  - c. the right laser on the lateral knee
3. The Erchonia Laser is activated.
4. The laser diodes laze each of these 3 areas for 10 minutes simultaneously.
5. The patient rises and leaves the procedure administration room.

## **ANKLE/FOOT PROTOCOL**

The protocol is as follows:

1. The patient enters the procedure administration room and is seated on a chair with the afflicted foot/heel elevated, or lays face up on a table.
2. The administrator positions one of each of the 3 laser lights between 3 and 4 inches away from, but directed toward,
  - a. the left laser on the medial ankle
  - b. the center laser on the top of the foot (dorsal aspect);
  - c. the right laser on the lateral ankle
3. The Erchonia Laser is activated.
4. The laser diodes laze each of these 3 areas for 10 minutes simultaneously.
5. The patient rises and leaves the procedure administration room.

## **PRE-OP PROTOCOL**

- Each laser procedure administration lasts 4 minutes.

The protocol is as follows:

1. The patient enters the procedure administration room and is seated on a chair, lays face up on a table or lays face down on a table.
2. The administrator turns ON or OFF the applicable lasers, depending upon the surgical area being treated.
3. The administrator positions one, two or all three of the laser lights between 3 and 4 inches away from, but directed toward, surgical area being treated.
4. The Erchonia Laser is activated.
5. The laser diodes laze each of these 3 areas for 4 minutes simultaneously.
6. The patient rises and leaves the procedure administration room.

## **POST-OP PROTOCOL**

- Each laser procedure administration lasts 4 minutes.

The protocol is as follows:

1. The patient enters the procedure administration room and is seated on a chair, lays face up on a table or lays face down on a table.
2. The administrator turns ON or OFF the applicable lasers, depending upon the surgical area being treated.
3. The administrator positions one, two or all three of the laser lights between 3 and 4 inches away from, but directed toward, surgical area being treated.
4. The Erchonia Laser is activated.
5. The laser diodes laze each of these 3 areas for 4 minutes simultaneously.
6. The patient rises and leaves the procedure administration room.

## **USER PROTOCOLS**

- Each laser procedure administration lasts 1-20 minutes, depending upon the programmed pain indication.

The protocol is as follows:

1. The patient enters the procedure administration room and is seated on a chair, lays face up on a table or lays face down on a table.
2. The administrator turns ON or OFF the applicable lasers, depending upon the programmed pain indication and the area of pain being treated.
3. The administrator positions one, two or all three of the laser lights between 3 and 4 inches away from, but directed toward, area of pain.
4. The Erchonia Laser is activated.
5. The laser diodes laze each of these 3 areas for 1-20 minutes simultaneously.
6. The patient rises and leaves the procedure administration room.

## **QUICK PROGRAM PROTOCOL**

- Each laser procedure administration lasts 1-20 minutes, depending upon the programmed pain indication.

The protocol is as follows:

1. The patient enters the procedure administration room and is seated on a chair, lays face up on a table or lays face down on a table.
2. The administrator turns ON or OFF the applicable lasers, depending upon the programmed pain indication and the area of pain being treated.
3. The administrator positions one, two or all three of the laser lights between 3 and 4 inches away from, but directed toward, area of pain.
4. The Erchonia Laser is activated.
5. The laser diodes laze each of these 3 areas for 1-20 minutes simultaneously.
6. The patient rises and leaves the procedure administration room.

## CLINICAL TRIAL SUMMARIES

### NECK AND SHOULDER PAIN

This pivotal study was a prospective, multi-center (3 U.S. sites), randomized, double-blinded, placebo-controlled multi-arm study of 100 subjects, of which 50 were randomized to the active treatment group and 50 were randomized to the control (placebo) group.

The device was administered to the sagittal suture (top of head); left and right cervical, shoulder and torso areas; right and left shoulders during each of passive external rotation and passive adduction of the arm and shoulder; right and left cervical muscles and trapezius muscles during passive left lateral flexion of the cervical spine; and the right and left sternocleidomastoid and scalene muscles during passive range of motion, for a total of 13 minutes during a single treatment administration.

Subjects were adults with neck and shoulder pain of musculoskeletal origin (osteoarthritis, chronic muscle spasms and cervical and thoracic spine sprain strain) ongoing for at least 30 days, and a rating of 50 or greater on the 0-100 Visual Analog Pain scale (VAS). Average duration of neck and/or shoulder pain at study entry was about 6 years.

#### **Primary effectiveness endpoint**

The primary efficacy endpoint was immediately following the single device treatment administration relative to baseline. The primary efficacy measure was the change in neck and shoulder pain rating as recorded on the 0-100 VAS.

Individual subject success was defined as a 30% or greater improvement (decrease) in the primary efficacy measure from baseline to endpoint. Study success was defined as a minimum 30% difference between treatment groups, comparing the proportion of individual successes.

Study results demonstrated that 65.1% of actively treated subjects attained individual success compared with 11.6% of control (placebo) subjects, resulting in a 53.5% difference between treatment groups, exceeding the 30% criteria by 23.5% ( $p < 0.0001$ ). Hence the study met its primary efficacy endpoint. The magnitude of the mean change in neck and shoulder pain VAS rating at endpoint relative to baseline was -29.02 for actively-treated subjects and -4.91 for control (placebo) subjects, a 20.08 difference ( $p < 0.0005$ ).

#### **Primary safety endpoint**

The primary safety endpoint consisted of all treatment-related adverse events. No treatment-related adverse event was reported or observed for any subject throughout study duration, and no other safety issues occurred; therefore, device safety is supported through these study results.

## **POST-OPERATIVE PAIN FOLLOWING LIPOSUCTION**

This pivotal study was a prospective, multi-center (3 U.S. sites), randomized, double-blinded, placebo-controlled multi-arm study of 70 subjects, of which 36 were randomized to the active treatment group and 34 were randomized to the control (placebo) group. The device was administered to each treatment area pre-surgery, separately, for 12 minutes per area.

Subjects were aged 18 to 55 years and satisfied the medical criteria for the indication of liposuction of the waist and/or hips and/or thighs.

### **Primary effectiveness endpoint**

The primary efficacy endpoint was 24 hours post-surgery. The primary efficacy measure was the subject's 24-hour post-surgery pain rating as recorded on the 0-100 VAS. Individual subject success was defined as a 24-hour post-treatment VAS rating of less than 30%. Study success was defined as a minimum 30% difference between treatment groups, comparing the proportion of individual successes.

Study results demonstrated that 75% of actively treated subjects attained individual success compared with 32% of control (placebo) subjects, resulting in a 43% difference between treatment groups, exceeding the 30% criteria by 14% ( $p < 0.005$ ). Hence the study met its primary efficacy endpoint. The mean VAS rating at 24 hours post-treatment was 24.56 for actively-treated subjects and 47.41 for control (placebo) subjects, a 22.85 difference ( $p < 0.001$ ).

### **Primary safety endpoint**

The primary safety endpoint consisted of all treatment-related adverse events. No treatment-related adverse event was reported or observed for any subject throughout study duration, and no other safety issues occurred; therefore, device safety is supported through these study results.

## **POST-OPERATIVE PAIN FOLLOWING BREAST AUGMENTATION**

This pivotal study was a prospective, multi-center (2 U.S. sites), randomized, double-blinded, placebo-controlled multi-arm study of 104 subjects, of which 50 were randomized to the active treatment group and 50 were randomized to the control (placebo) group. The device treatment was administered to each breast for 4 minutes per breast pre-surgery and again post-surgery. Two additional treatments were administered at 24 hours and one-week post-surgery, for 4 minutes per breast.

Subjects were aged 18 to 55 years and satisfied the medical criteria for the indication of bilateral breast augmentation surgery. Subjects were predominantly Caucasian (96%).

### **Primary effectiveness endpoint**

The primary efficacy endpoint was 24 hours post-surgery. The primary efficacy measure was the subject's 24-hour post-surgery pain rating as recorded on the 0-100 VAS. Individual subject success was defined as a 24-hour post-treatment VAS rating of less than 30%. Study success was defined as a minimum 30% difference between treatment groups, comparing the proportion of individual successes.

Study results demonstrated that 74% of actively treated subjects attained individual success compared with 37% of control (placebo) subjects, resulting in a 37% difference between treatment groups, exceeding the 30% criteria by 7% ( $p < 0.005$ ). Hence the study met its primary efficacy endpoint. The mean VAS rating at 24 hours post-treatment was 21.4 for actively-treated subjects and 36.78 for control (placebo) subjects, a 15.38 difference ( $p < 0.001$ ).

### **Primary safety endpoint**

The primary safety endpoint consisted of all treatment-related adverse events. No treatment-related adverse event was reported or observed for any subject throughout study duration, and no other safety issues occurred; therefore, device safety is supported through these study results.

## HEEL PAIN FROM PLANTAR FASCIITIS

This pivotal study was a prospective, multi-center (2 U.S. sites), randomized, double-blinded, placebo-controlled multi-arm study of 69 subjects, of which 37 were randomized to the active treatment group and 32 were randomized to the control (placebo) group. The device was administered across the top of the foot (dorsal aspect), the myofascial junction of the heel, and the plantar aspect of the heel, simultaneously, for ten minutes per treatment: two treatments per week, each three of four days apart, across a consecutive three-week period, for a total of six treatments.

Subjects were adults with unilateral mechanical plantar heel pain of at least three months duration and a rating of 50 or greater on the Visual Analog Pain scale (VAS) with failure to respond to prescription non-steroidal anti-inflammatory drugs (NSAIDs) and two or more additional conservative treatment approaches. Subjects averaged 56.29 years, were predominantly Caucasian (90%), with a 2:3 ratio of females to males (39% versus 61%). Average duration of heel pain at study entry was 12.29 months.

### **Primary effectiveness endpoint**

The primary efficacy endpoint was two weeks after treatment end relative to baseline. The primary efficacy measure was the change in 2-day average first steps of the day heel pain as recorded on the 0-100 VAS.

Individual subject success was defined as a 30% or greater improvement (decrease) in the primary efficacy measure from baseline to endpoint. Study success was defined as a minimum 35% difference between treatment groups, comparing the proportion of individual successes.

Study results demonstrated that 62% of actively treated subjects attained individual success compared with 12.5% of control (placebo) subjects, resulting in a 49.5% difference between treatment groups, exceeding the 30% criteria by 19.5% ( $p < 0.00005$ ). Hence the study met its primary efficacy endpoint. The magnitude of the mean change in 2-day average first steps of the day heel pain VAS rating at endpoint relative to baseline was -29.47 for actively-treated subjects and -5.38 for control (placebo) subjects, a 24.09 difference ( $p < 0.0001$ ).

### **Primary safety endpoint**

The primary safety endpoint consisted of all treatment-related adverse events. No treatment-related adverse event was reported or observed for any subject throughout study duration, and no other safety issues occurred; therefore, device safety is supported through these study results.

## LOW BACK PAIN

This pivotal study was a prospective, multi-center (3 U.S. sites), randomized, double-blinded, placebo-controlled multi-arm study of 58 subjects, of which all 29 were randomized to the active treatment group and 29 were randomized to the control (placebo) group. The device was administered across the lower back region for twenty minutes per treatment: two treatments per week, each three of four days apart, across a consecutive four-week period, for a total of eight treatments.

Subjects were adults with episodic chronic low back pain of musculoskeletal origin of lumbar sprain or strain etiology and a low back pain rating of 40 or greater on the 0 to 100 VAS scale.

Subjects averaged 45.57 years, were predominantly Caucasian (69%) followed by Hispanic (14%), African American (8.5%) and Asian (8.5%), with equal distribution of males and females (47% versus 53%). Average duration of low back pain at study entry was just over 8 years.

### **Primary effectiveness endpoint**

The primary efficacy endpoint was two months after treatment end relative to baseline. The primary efficacy measure was the change in low back pain rating as recorded on the 0-100 VAS. Individual subject success was defined as a 30% or greater improvement (decrease) in the primary efficacy measure from baseline to endpoint. Study success was defined as a minimum 35% difference between treatment groups, comparing the proportion of individual successes.

Study results demonstrated that 72.4% of actively treated subjects attained individual success compared with 27.6% of control (placebo) subjects, resulting in a 44.8% difference between treatment groups, exceeding the 30% criteria by 14.8% ( $p < 0.005$ ). Hence the study met its primary efficacy endpoint. The magnitude of the mean change in low back pain VAS rating at endpoint relative to baseline was -34.24 for actively-treated subjects and -10.97 for control (placebo) subjects, a 23.37 difference ( $p < 0.001$ ).

### **Primary safety endpoint**

The primary safety endpoint consisted of all treatment-related adverse events. No treatment-related adverse event was reported or observed for any subject throughout study duration, and no other safety issues occurred; therefore, device safety is supported through these study results.

## SECTION 5 MAINTENANCE & WARRANTY INFORMATION

### MAINTENANCE AND CLEANING

#### DEVICE MAINTENANCE

The Erchonia<sup>®</sup> Laser, if used according to the instructions contained within this manual, will operate efficiently for years. To ensure proper care, it is advisable for the end user to perform:

1. Regular visual inspections to ensure there is no external damage other than normal wear and tear. Inspect all cords for signs of excessive wear (cuts in insulation or fraying). If during these inspections, you identify an area of concern, please contact the manufacturer to determine if action is required.
2. If you notice a change in the performance of the device, while in the ON position, please contact the manufacturer to determine if action is required.
3. The internal components should not require any maintenance, however if an issue arises, which will show itself in the form of altered performance, the device must be sent to the manufacturer.
4. Since the device contains a touchscreen interface, periodic cleaning of the touchscreen will be necessary. To clean the touchscreen, use a nearly dry cloth containing one of the mild cleaning agents listed below. Ensure there is **NOT** an excess of fluid.
5. The PCB back up battery must be replaced every five years. This must be done by manufacturer.

#### FUSE REPLACEMENT

Replacing the fuses is the only service that can be conducted by the end-user.

To replace the fuses, unplug the AC power cord and open the fuse carrier door located in the power inlet module with a small flathead screwdriver. Remove old fuses and insert new ones in place. Close fuse box.

Use only Fuses Type: T2AH 250V Rated at 250vAC, 2A; 5 x 20mm with an input to cover 1.5A/100VAC & 0.5A/240VAC, 50&60 Hz.

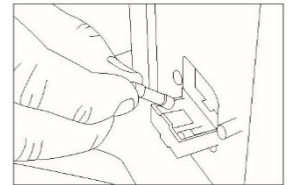
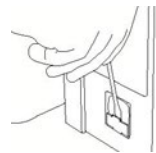

#### ROUTINE USER MAINTENANCE

Clean the external surfaces of the device	Weekly, or as needed
Clean the touch screen display	Weekly, or as needed
Clean Laser optics	Weekly, or as needed
Clean Laser glasses	Between each patient use

#### CLEAN THE EXTERNAL SURFACES OF THE DEVICE

Use a cloth dampened with non-caustic cleaning solution, such as mild soap and water, isopropyl alcohol, or a “hospital-grade” disinfectant, to wipe the external surfaces of the device. Dry with a clean cloth or allow to air dry.



**DO NOT** permit any foreign materials or liquids to enter the device. Take care to prevent any foreign materials including, but not limited to, inflammables, water, and metallic objects from entering the device. These may cause device damage, malfunction, electrical shock, fire, or personal injury. To achieve the specified level of protection against spilled or splashed liquids, unplug the device from the power supply and thoroughly dry all exposed surfaces of this device and allow to dry thoroughly prior to operation.

### *CLEAN THE TOUCH SCREEN DISPLAY*

Apply an alcohol-based cleaner to a soft cloth to clean the touch screen display.



**DO NOT** spray or pour cleaning agents directly on the device or touch screen. You may damage the console, touchscreen, and the system electronics.

### *LASER OPTICS CLEANING*

Use lens paper or lens cloth **ONLY**. Abrasive material could cause laser light beam fragmentation, which may reduce the effectiveness of the treatment.

### *LASER GLASSES CLEANING*

Use only mild soap, warm water and soft cloth to clean. **DO NOT USE CLEANING SOLVENTS**

## **WARRANTY**

### *LIMITED WARRANTY*

The Erchonia<sup>®</sup> laser device is warranted to be free from defect in material and workmanship for a period of TWO YEARS from the date of purchase.

For your device to be processed through the Service and Repair Department efficiently, contact the department prior to submitting your product. Repairs and Warranty work NOT coordinated through the Service and Repair Department prior to receipt can be delayed.

Items being sent in from overseas require special paperwork, available through the warranty department, if this paperwork is not obtained prior to shipping; your package will be delayed by customs.

### *TERMS AND CONDITIONS*

- Shipping required to facilitate warranty repair and or maintenance issues within the first 90-days, will be paid by manufacturer.
- Shipping required to facilitate warranty repair and or maintenance issues after 90-days, is the financial responsibility of the customer.
- Warranties of Erchonia Corporation products are not transferable unless sold by a company-approved distributor, reseller and/or leasing company.
- The warranty DOES NOT cover instances involving or damages resulting from:
  - Accident, misuse or abuse
  - Lack of responsible care
  - Alteration or disassembly
  - Loss of parts
  - Exposure to the elements
  - Ingress of liquid
  - Exposure to excessive electromagnetic frequency

### *PRODUCT CHANGES*

Erchonia Corporation reserves the right to make changes and improvements to its products without incurring any obligation to incorporate such improvements in products previously sold.

## CONTACT US

Questions? If for any reason you are dissatisfied with this product, warranty concerns or questions regarding proper operation, please contact our Erchonia® Customer Care representative for assistance. Contact us at:

**Erchonia Customer Care**

Phone: 1-321-473-1251

Email: [info@erchonia.com](mailto:info@erchonia.com)

Or visit [erchonia.com](http://erchonia.com)

Copyright © 2017

Erchonia Corporation

All rights reserved

Protected by US Patents #s 6,013,096; US PAT 6,746,473, for additional US and International patents and patent pending go to [www.erchonia.com](http://www.erchonia.com)

### TROUBLESHOOTING

Use the following information to help solve problems that may arise during use. If you still have questions, please call Erchonia Customer Care, and we will be happy to help.

Problem	Possible Cause	How to Resolve
<b>POWER</b> Device does not power on	AC power cord not plugged into device or power outlet.	Connect power cord.
	Blown fuse within device.	Replace using the correct fuses.
	Lockout key not positioned correctly.	(“O” = OFF and “ ” = ON)
	Tripped circuit breaker or blown fuse within your building.	Contact a qualified electric service technician.
Diode(s) does not power on	Individual Laser head is switched to off	Turn laser head to the “ ” ON position within the specific protocol in which it was switched off.
	Out of Credits	Contact Erchonia Sales Support to purchase credits

# LASER HEAD ASSEMBLY REMOVAL & INSTALLATION FOR SERVICE

## LASER HEAD ASSEMBLY REMOVAL FOR SERVICE



**DO NOT** remove the Laser Head Assembly unless authorized by the Erchonia Service Department.

The Laser Head Assembly can be removed from the device for service with authorization from the Erchonia Service Department. Follow the steps below in order to remove the laser head assembly from the device.

1. **Ensure the Main Arm is fully extended and all the way up throughout all steps.**
2. Lock all four Wheels.
3. Unplug the Power Cord from the wall socket and unplug the other end of the power cord from the device.
4. Using a small tool, pry off the label from the Main Arm as shown (**Image A**).
5. Grab the connectors with both hands (**do not grab or pull on the wires**) and unplug the connectors from each other as shown (**Image B**) by pressing on the connector tab and pulling connectors apart from each other.
6. Hold the Laser Head Assembly Handle with one hand for support (or have another person hold handle for support) and then unscrew and remove both screws as shown (**Image C**) using a 5/32 Allen Driver (**continue holding handle for support**).
7. Remove the Laser Head Assembly from the Main Arm by pulling off the head assembly (**Image D**), ensuring wires do not get damaged or caught between parts while dis-assembling.

**Image A**

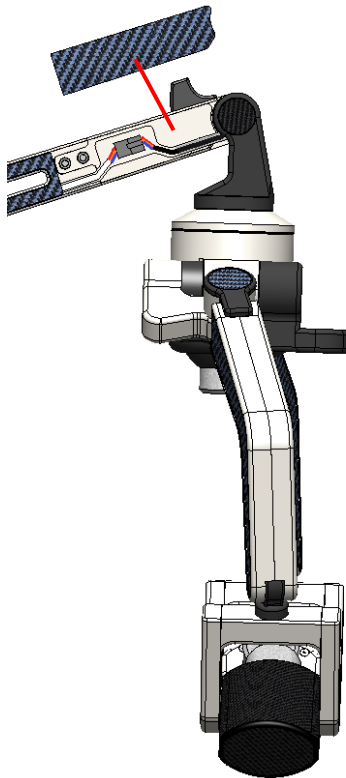

**Image B**

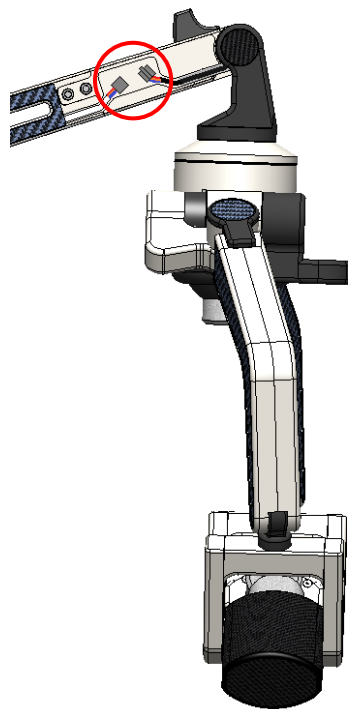

**Image C**

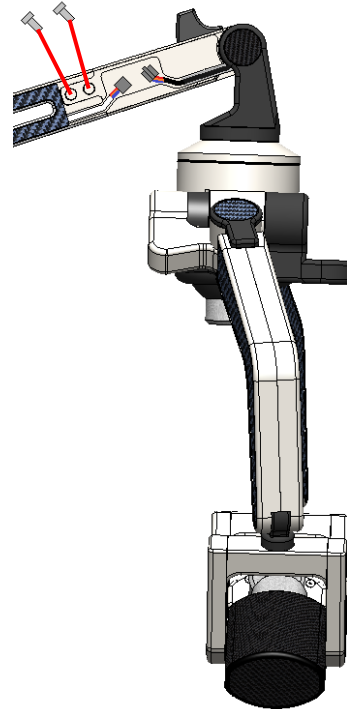

**Image D**

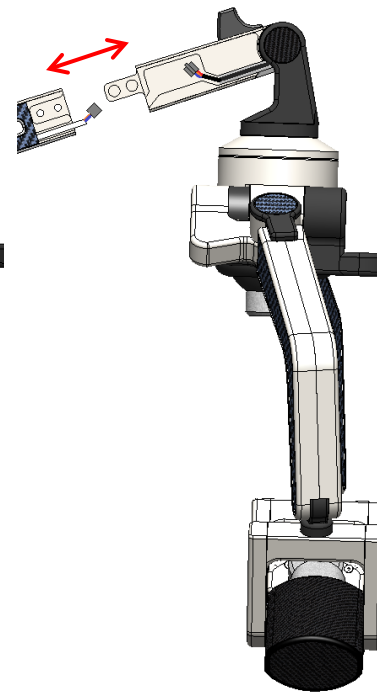

## LASER HEAD ASSEMBLY INSTALLATION FOR SERVICE



**DO NOT** install the Laser Head Assembly unless authorized by the Erchonnia Service Department.

The Laser Head Assembly can be installed onto the device for service with authorization from the Erchonnia Service Department. Follow the steps below in order to install the laser head assembly onto the device.

1. **Ensure the Main Arm is fully extended and all the way up throughout all steps.**
2. Lock all four Wheels.
3. Unplug the Power Cord from the wall socket and unplug the other end of the power cord from the device.
4. Install Laser Head Assembly into Main Arm by inserting laser head assembly extrusion into main arm pocket as shown (**Image A**) until screw holes on both components are aligned and flush with each-other ensuring wires do not get damaged or caught between parts while installing; hold the Laser Head Assembly Handle for support (or have another person hold handle for support) until components are screwed together.
5. Install and screw both screws into components as shown (**Image B**) using a 5/32 Allen Driver until screws are fully secure.
6. Grab both connectors and plug into each-other until they click into place as shown (**Image C**) (connectors only have one insertion direction).
7. Remove adhesive liner from label (if applicable) and adhere as shown (**Image D**).

**Image A**

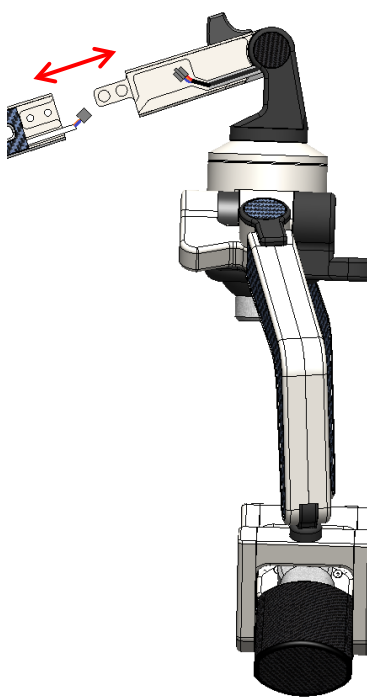

**Image B**

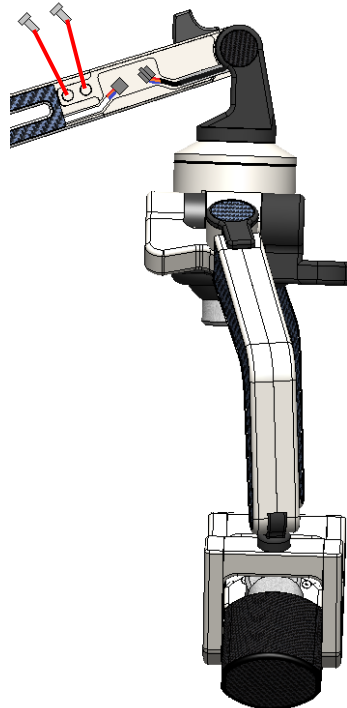

**Image C**

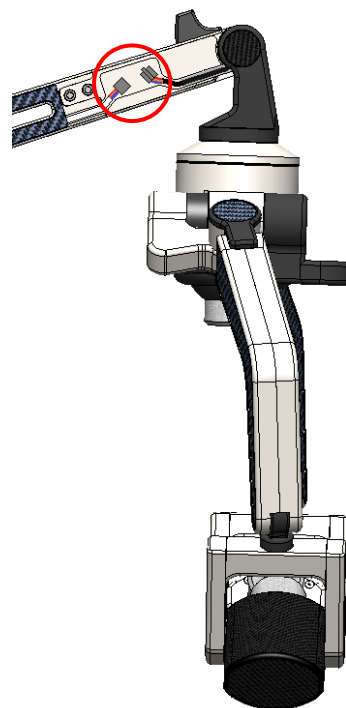

**Image D**

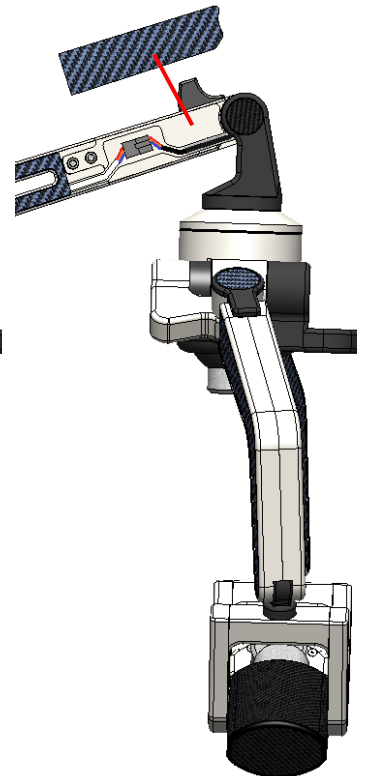

## **GUIDANCE AND MANUFACTURER’S DECLARATION-ELECTROMAGNETIC EMISSIONS & IMMUNITY**

Medical electrical equipment needs special precautions regarding EMC and needs to be installed and put into service according to EMC information provided in this document. Portable and mobile RF communications equipment can affect the medical electrical equipment.

This declaration currently applies to the Erchonia® [HPS] device.

### **GUIDANCE AND MANUFACTURER’S DECLARATION-ELECTROMAGNETIC EMISSIONS**

The device is intended for use in the electromagnetic environment specified below. The customer or the user of the device should assure that it is used in such an environment.

<b>Emissions test</b>	<b>Compliance</b>	<b>Electromagnetic environment-guidance</b>
RF emissions CISPR 11	Group 1	The device uses RF energy only for its internal function. Therefore, its RF emissions are very low and are not likely to cause any interference in nearby electronic equipment.
RF emissions CISPR 11	Class B	The device is suitable for use in all establishments, including domestic establishments and those directly connected to the public low voltage power supply network that supplies buildings used for domestic purposes.
Harmonic Emissions IEC 61000-3-2	Class A	
Voltage Fluctuations/Flicker Emissions IEC 61000-3-3	Complies	

#### **WARNING**

- This device should not be used adjacent to other equipment. If adjacent use is necessary, the device should be observed to verify normal operation in the configuration in which it will be used.
- The use of accessories other than those specified for the device is not recommended. They may result in increased emissions or decreased immunity of the device.

## GUIDANCE AND MANUFACTURER'S DECLARATION-ELETROMAGNETIC IMMUNITY

The device is intended for use in the electromagnetic environment specified below. The customer or the user of the device should assure that the device is used in such an environment.

Immunity test	IEC60601-1-2 test level	Compliance level	Electromagnetic environment-guidance
Electrostatic discharge (ESD) IEC 61000-4-2	± 8 kV contact ± 15 kV air	± 8 kV contact ± 15 kV air	Floors should be wood, concrete or ceramic tile. If floors are covered with synthetic material, the relative humidity should be at least 30 %.
Electrical fast transient/burst IEC 61000-4-4	± 2 kV for power supply lines ± 1 kV for input/output lines	± 2 kV for power supply lines ± 1 kV for input/output lines	Mains power quality should be that of a typical commercial or hospital environment.
Surge IEC 61000-4-5	± 1 kV line(s) to line(s) ± 2 kV line(s) to earth	± 1 kV differential mode ± 2 kV common mode	Mains power quality should be that of a typical commercial or hospital environment.
Voltage dips, short interruptions and voltage variations on power supply input lines IEC 61000-4-11	<5% $U_T$ (>95% dip in $U_T$ ) for 0.5 cycle 40% $U_T$ (60% dip in $U_T$ ) for 5 cycles 70% $U_T$ (30% dip in $U_T$ ) for 25 cycles <5% $U_T$ (>95% dip in $U_T$ ) for 5 sec	<5% $U_T$ (>95% dip in $U_T$ ) for 0.5 cycle 40% $U_T$ (60% dip in $U_T$ ) for 5 cycles 70% $U_T$ (30% dip in $U_T$ ) for 25 cycles <5% $U_T$ (>95% dip in $U_T$ ) for 5 sec	Mains power quality should be that of a typical commercial or hospital environment. If the user of the device requires continued operation during power mains interruptions, it is recommended that the device be powered from an uninterruptible power supply.
Power frequency (50/60 Hz) magnetic field IEC 61000-4-8	30 A/m	30 A/m	Power frequency magnetic fields should be at levels characteristic of a typical location in a typical commercial or hospital environment.  Portable and mobile RF communications equipment should be used no closer to any part of the device including cables, than the recommended separation distance calculated from the equation applicable to the frequency of the transmitter.  <b>Recommended separation distance</b>
Conducted RF IEC 61000-4-6	3 Vrms 150 kHz to 80 MHz	3 Vrms	$d = 1.2\sqrt{P}$
Radiated RF IEC 61000-4-3	10 V/m 80 MHz to 2.7 GHz	10 V/m	$d = 1.2\sqrt{P}$ 80 MHz to 800 MHz
			$d = 2.3\sqrt{P}$ 800 MHz to 2.5 GHz  where $P$ is the maximum output power rating of the transmitter in watts (W) according to the transmitter manufacturer and $d$ is the recommended separation distance in meters (m). Field strengths from fixed RF transmitters, as determined by an electromagnetic site survey, <sup>a</sup> should be less than the compliance level in each frequency range. <sup>b</sup> Interference may occur in the vicinity of equipment marked with the following symbol: 

<sup>a</sup> Field strengths from fixed transmitters, such as base stations for radio (cellular/cordless) telephones and land mobile radios, amateur radio, AM and FM radio broadcast and TV broadcast cannot be predicted theoretically with accuracy. To

assess the electromagnetic environment due to fixed RF transmitters, an electromagnetic site survey should be considered. If the measured field strength in the location in which the [HPS] is used exceeds the applicable RF compliance level above, the device should be observed to verify normal operation. If abnormal performance is observed, additional measures may be necessary, such as re-orienting or relocating the device.

<sup>b</sup> Over the frequency range 150 kHz to 80 MHz, field strengths should be less than 3 V/m.

**Notes:**

- $U_T$  is the AC mains voltage prior to application of the test level.
- At 80 MHz and 800 MHz, the higher frequency range applies.
- These guidelines may not apply in all situations. Electromagnetic propagation is affected by absorption and reflection from structures, objects and people.

**RECOMMENDED SEPARATION DISTANCES BETWEEN PORTABLE AND MOBILE RF COMMUNICATIONS EQUIPMENT AND THE DEVICE.**

The device is intended for use in an electromagnetic environment in which radiated RF disturbances are controlled. The customer or the user of the device can help prevent electromagnetic interference by maintaining a minimum distance between portable and mobile RF communications equipment (transmitters) and the device as recommended below, according to the maximum output power of the communications equipment.

Rated maximum output power of transmitter (W)	Separation distance according to frequency of transmitter (m)		
	150 kHz to 80 MHz $d = 1.2\sqrt{P}$	80 MHz to 800 MHz $d = 1.2\sqrt{P}$	800 MHz to 2.5 GHz $d = 2.3\sqrt{P}$
<b>0.01</b>	0.12	0.12	0.23
<b>0.1</b>	0.38	0.38	0.73
<b>1</b>	1.2	1.2	2.3
<b>10</b>	3.8	3.8	7.3
<b>100</b>	12	12	23

For transmitters rated at a maximum output power not listed above, the recommended separation distance  $d$  in meters (m) can be estimated using the equation applicable to the frequency of the transmitter, where  $P$  is the maximum output power rating of the transmitter in watts (W) according to the transmitter manufacturer.

**Notes:**

- At 80 MHz and 800 MHz, the separation distance for the higher frequency range applies.
- These guidelines may not apply in all situations. Electromagnetic propagation is affected by absorption and reflection from structures, objects and people.

# TECHNICAL SPECIFICATIONS

## Relevant Information



Erchonia Corporation  
650 Atlantis Rd.  
Melbourne, FL 32904 USA



QNET BV  
Kantstraat 19  
NL-5076 NP Haaren  
The Netherlands



**Trade Name: Erchonia® FX 635**  
**Model Number: HPS**

## Classifications

### US

- Device Class: II
- Laser Class: 2

### EU

- Device Class: II
- Laser Class: 2

### UL/CSA

- Electrical Class 1

### International

- Device Class: II
- Laser Class: 2

## Applicable Codes

### FDA

21CFR 820 – Quality System Regulations  
21CFR 1040.10 and 1040.11 by laser Notice 50

### ISO

13485 – Medical Device Quality  
14971 – Risk Management

EMC 2014/30/EU  
LVD 2014/35/EU  
IEC 60601-1-2 EMC  
IEC 60601-1 Safety  
IEC 60825-1 – Laser Safety  
CB Certified

## Specifications

### Device

- Weight: 81.6lbs / 37kg
- Height: 62 in / 157.48 cm (Fully Extended)
- Full Color Touch Screen Control Center
- Two Independent Adjustable Arms For Desired Laser Concentration
- 4 Locking Anti-Static Casters
- Powder Coated Metal Frame
- Non-Allergenic Material
- Leakage Current 0.3 -0.5  $\mu$ A (Micro Amps)
- Applied Part: Type B

### Laser

- Qty: 3, Class 2 Line Generating Diode Modules
- Output: 17.25mW  $\pm$  1.25mW
- Wavelength: 640 nm  $\pm$ 10nm
- Modulation: Constant Wave-50% Duty Cycle

### Power

- Source: 100-240VAC, 50-60Hz, 1.5-0.5A
- Fuse Type: T2AH 250V
- Fuse Rating: 250V, 2A

### Temperature

- Operating Temp: 59 to 85°F (15 to 29°C) Relative Humidity: <50%
- Transporting: -22 to 158°F (-30 to 70°C) Relative Humidity: <75% non-condensing

### Atmospheric Pressure (Altitude)

- Rated operating altitude  $\leq$  2000 m
- Pressure Range 80.0kPa- 105kPa

## Legend:

FDA – US Food & Drug Administration, which includes the CDRH (Center for Device Radiological Health)

ISO – International Standards, Harmonized with US, Canadian, European and Asian standards

Doc No.	CR No.	Rev. Level	Rev. Date
OM-HPS2-C	<b>Production Release</b>	01	03/19/2019
OM-HPS2-C	<b>58-19-ENG</b>	02	01/16/2020
OM-HPS2-C	<b>08-22-ADM</b>	03	03/18/2022



**ERCHONIA**  
*World Leaders in Low Level Laser Technology*

**FX635**

**Learn more about  
Erchonia lasers**



Scan with **RedLaser**

[erchonia.com](http://erchonia.com) | 1-321-473-1251 US

# Other ManualsLib Projects



[www.manualslib.com](http://www.manualslib.com)



[www.manualslib.de](http://www.manualslib.de)



[www.manualslib.es](http://www.manualslib.es)



[www.manualslib.fr](http://www.manualslib.fr)



[www.manualslib.nl](http://www.manualslib.nl)



[www.manualslib.mx](http://www.manualslib.mx)



[www.manualslib.tech](http://www.manualslib.tech) 30+ Languages